

# Selection Guide

## Anchors for Concrete Applications

ANCHOR TYPE		KEY FEATURES	SIZE RANGE (Inches)
	<b>Trubolt</b> <sup>®</sup> Wedge Anchors 	<ul style="list-style-type: none"> <li>2015 IBC Compliant</li> <li>Seismic zone (A-B) approved</li> <li>Fully-threaded</li> <li>Length ID head stamped</li> <li>Stainless steel clip</li> <li>Through-fixture fastening</li> </ul>	<b>Diameter:</b> 1/4 – 1 <b>Length:</b> 1-3/4 – 12
	<b>Trubolt</b> <sup>®</sup> + Seismic Wedge Anchors  ID STAMP	<ul style="list-style-type: none"> <li>2015 IBC Compliant</li> <li>All seismic zone (A-F) and cracked concrete approved</li> <li>Fully-threaded</li> <li>Length ID head stamped</li> <li>Through-fixture fastening</li> </ul>	<b>Diameter:</b> 3/8, 1/2, 5/8 & 3/4 <b>Length:</b> 3 – 8-1/2
	<b>Trubolt</b> <sup>®</sup> + SS Seismic Wedge Anchors  (see page 72)	<ul style="list-style-type: none"> <li>2015 IBC Compliant</li> <li>ICC-ES ESR 2427 for Cracked and Uncracked Concrete</li> <li>Patented grooved clip design</li> <li>Meets ductility requirements of ACI 318 D.3.3</li> <li>Fully threaded</li> <li>Anchor body and clip are Made in the U.S.A.</li> </ul>	<b>Diameter:</b> 1/2 and 5/8 <b>Length:</b> 3-3/4 - 7
	<b>Large Diameter Tapcon (LDT) and LDTX</b> Self-Threading Anchor 	<ul style="list-style-type: none"> <li>Anti-rotation serrated washer</li> <li>Extra large hex washer head</li> <li>Length ID head stamped</li> <li>Through-fixture fastening</li> </ul>	<b>LDT with Zinc Plating</b> <b>Diameter:</b> 3/8 – 3/4 <b>Length:</b> 1-3/4 – 6-1/4  <b>LDTX with EnvireX Coating</b> <b>Diameter:</b> 3/8 & 1/2 <b>Length:</b> 3 – 5
	<b>Tapcon</b> <sup>®</sup> + Self-Threading Anchor 	<ul style="list-style-type: none"> <li>Approved for concrete in uncracked, cracked, and seismic conditions</li> <li>Easy installation</li> <li>Blue Climaseal for superior corrosion resistance</li> <li>Removable</li> </ul>	<b>Diameter:</b> 1/4 – 1/2 <b>Length:</b> 2-1/4 – 6
	<b>Boa</b> <sup>™</sup> Coil Expansion Anchors 	<ul style="list-style-type: none"> <li>Heavy-Duty, Reusable Fastening</li> <li>Easy installation</li> <li>Removable</li> <li>High shear strength</li> <li>Zinc plated carbon steel to ASTM B633, SC1, Type III</li> </ul>	<b>Diameter:</b> 1/2 – 3/4 <b>Length:</b> 3 – 6
	<b>Multi-Set II</b> <sup>®</sup> Drop-In Anchors  RM RL RX CL	<ul style="list-style-type: none"> <li>RM: Flanged body to keep anchor flush with surface of concrete</li> <li>RL: Non-flanged body for recessed setting</li> <li>RX: Designed for hollow core and post tension concrete</li> <li>CL: Designed for one-sided forming, accepts coil rod</li> </ul>	<b>Diameter:</b> 1/4 – 3/4 <b>Length:</b> 1 – 3-3/16 <hr/> <b>Diameter:</b> 1/4 – 3/4 <b>Length:</b> 1 – 3-3/16 <hr/> <b>Diameter:</b> 3/8 & 1/2 <b>Length:</b> 3/4 - 1 <hr/> <b>Diameter:</b> 1/2 & 3/4 <b>Length:</b> 2 & 3-3/16

	CORROSION RESISTANCE	PERFORMANCE	HEAD STYLES	APPROVALS/LISTINGS
<b>Trubolt</b> cont'd	<ul style="list-style-type: none"> <li>■ Zinc-plated carbon steel to ASTM B633, SC1, Type III</li> <li>■ Hot dipped galvanized to ASTM A-153</li> <li>■ Type 304 and 316 stainless steel</li> </ul>	Ultimate Pullout Performance in 4000 psi Concrete up to 26,540 lbs. (1" diameter)	Hex nut Tie-Wire version	ICC Evaluation Service, Inc. ESR-2251 Underwriters Laboratories Factory Mutual Caltrans Meets or exceeds U.S. Government G.S.A. Specification A-A-1923A Type 4 (formerly GSA: FF-S-325 Group II, Type 4, Class 1)
<b>Trubolt+</b> cont'd	<ul style="list-style-type: none"> <li>■ Zinc-plated carbon steel to ASTM B633, SC1, Type III</li> </ul>	Pullout strength of 4,980 lbs in 2,500 psi Cracked Concrete (1/2" diameter).	Hex nut	ICC Evaluation Service, Inc. # ESR-2427 -Category 1 performance rating -2015 IBC compliant -Meets ACI 318 ductility requirements -Tested in accordance with ACI 355.2 & ICC-ES AC193 -Listed for use in seismic zones A, B, C, D, E, & F -3/8", 1/2", 5/8" and 3/4" diameter anchors listed in ESR-2427 City of Los Angeles - #RR25867 Florida Building Code (FBC)
<b>Trubolt+ SS</b> cont'd	<ul style="list-style-type: none"> <li>■ Stainless Steel AISI 316</li> </ul>	Pullout strength of 4,980 lbs in 2,500 psi Cracked Concrete (1/2" diameter).	Hex nut	ICC-ES ESR 2427 for cracked and uncracked concrete Approved for use in ALL SEISMIC ZONES (A-F) 2015 International Building Code (IBC) 2015 International Residential Code (IRC) Florida Building Code (FBC)
<b>LDT</b> cont'd	<ul style="list-style-type: none"> <li>■ Zinc-plated carbon steel to ASTM B695 &amp; B633</li> <li>■ Type 410 stainless steel</li> </ul> <hr/> <ul style="list-style-type: none"> <li>■ <b>EnvireX</b> coating</li> </ul> <p>Approved for use in ACQ and MCQ Lumber* *Excessive content of copper in the ACQ and MCQ lumber may affect the anchor finish.</p>	Ultimate Pullout Performance in 4,000 psi Concrete up to 23,266 lbs. (3/4" diameter)	Finished bolt style	1,000 hours salt spray ASTM B117
<b>Tapcon+</b> cont'd	<ul style="list-style-type: none"> <li>■ Blue Climaseal coated for superior corrosion resistance</li> </ul>	Ultimate Pullout Performance in 4000 psi Concrete up to 38,500 lbs. (3/4" diameter)	Finished bolt style	ICC-EC ESR 3699
<b>Multi-Set II Drop-In</b> cont'd	<ul style="list-style-type: none"> <li>■ Zinc-plated carbon steel to ASTM B633, SC1, Type III</li> <li>■ Type 304 and 316 stainless steel</li> </ul>	Ultimate Pullout Performance in 4000 psi Concrete up to 9,480 lbs. (3/4" diameter)	RM: Flanged body RL: Non-flanged body Use any bolt or threaded rod	GSA: A-A-55614 Type 1 (Formerly GSA: FF-S-325 Group VIII) Underwriters Laboratories Factory Mutual Caltrans
<b>Dynabolt</b> cont'd	<ul style="list-style-type: none"> <li>■ Zinc-plated carbon steel to ASTM B633, SC1, Type III</li> <li>■ Type 304 stainless steel</li> </ul>	Ultimate Pullout Performance in 4000 psi Concrete up to 8,900 lbs. (3/4" diameter)	Flat head Hex nut Acorn nut Tie-Wire Round head Threshold flat head	GSA: A-A-1922A (Formerly GSA: FF-S-325 Group II, Type 3, Class 3) Factory Mutual

# Anchors for Concrete Applications

continued from pages 50-51

ANCHOR TYPE	KEY FEATURES	SIZE RANGE (Inches)
<p><b>Tapcon®</b> Concrete Anchors with Advanced Threadform Technology™</p>  <p>Original      Maxi-Set      SCOTS      XL      StormGuard</p>		
<p><b>Hammer-Set™</b> Nail-drive Anchors</p> 	<ul style="list-style-type: none"> <li>■ Easy installation</li> <li>■ Low profile head</li> <li>■ Through-fixture fastening</li> </ul>	<p><b>Diameter:</b> 3/16 &amp; 1/4 <b>Length:</b> 7/8 – 2</p>
<p><b>Dynabolt®</b> Masonry Sleeve Anchors</p>  <p>For both Hollow and Solid Concrete Applications</p>	<ul style="list-style-type: none"> <li>■ Concrete, block and brick</li> <li>■ Many choices of head styles</li> <li>■ Through-fixture fastening</li> <li>■ Available in 304 stainless steel</li> </ul>	<p><b>Diameter:</b> 1/4 – 3/4 <b>Length:</b> 5/8 – 6-1/4</p>

	CORROSION RESISTANCE	PERFORMANCE	HEAD STYLES	APPROVALS/LISTINGS
<b>Tapcon</b> <i>cont'd</i>	<ul style="list-style-type: none"> <li>■ Patented Trade Secret Climaseal® coating</li> <li>■ Type 410 stainless steel</li> </ul> <p>The above is for the Original and 410 SS Tapcon only.            For data on other Tapcon products see their product pages as follows:            Tapcon Maxi-Set on page 94, Tapcon SCOTS on page 94, Tapcon XL on page 98, and Tapcon StormGuard on page 100.</p>	Ultimate Pullout Performance in 4000 psi Concrete up to 2,380 lbs.	Hex head Phillips flat head	<b>Blue Climaseal™</b> ICC Evaluation Service, Inc. – ESR-1671 ICC Evaluation Service, Inc. – ESR-2202 Miami-Dade County Florida Building Code <b>410 Stainless Steel</b> Miami-Dade County Florida Building Code
<b>Hammer-Set</b> <i>cont'd</i>	<ul style="list-style-type: none"> <li>■ Zinc alloy</li> </ul>	Ultimate Pullout Performance in 4000 psi Concrete up to 793 lbs.	Mushroom head	GSA: A-A-1925A Type 1 (zinc mushroom) (Formerly GSA: FF-S-325 Group V, Type 2, Class 3)
<b>Boa Coil</b> <i>cont'd</i>	<ul style="list-style-type: none"> <li>■ Zinc plated carbon steel to ASTM B633, SC1, Type III</li> </ul>	Ultimate Pullout Performance in 4000 psi Concrete up to 38,500 lbs. (3/4" diameter)	Finished bolt style	

Because applications vary, ITW RED HEAD cannot guarantee the performance of this product. Each customer assumes all responsibility and risk for the use of this product. The safe handling and the suitability of this product for use is the sole responsibility of the customer. Specific job site conditions should be considered when selecting the proper product. Should you have any questions, please call the Technical Assistance Department at 800-848-5611.

# Trubolt<sup>®</sup> Wedge Anchors

**Dependable,  
Heavy-Duty,  
Inspectable,  
Wedge Type  
Expansion  
Anchor**



**2015 IBC  
Compliant**

**Trubolt<sup>®</sup>**  
Wedge Anchors

## DESCRIPTION/SUGGESTED SPECIFICATIONS

### Wedge Type Anchors—

#### SPECIFIED FOR ANCHORAGE INTO CONCRETE

Trubolt Wedge anchors feature a stainless steel expansion clip, threaded stud body, nut and washer. Anchor bodies are made of plated carbon steel, hot-dipped galvanized carbon steel, type 304 stainless steel or type 316 stainless steel as identified in the drawings or other notations.

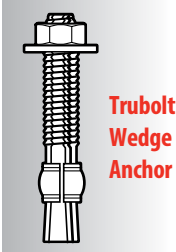

The exposed end of the anchor is stamped to identify anchor length. Stampings should be preserved during installation for any subsequent embedment verification.

Use carbide tipped hammer drill bits made in accordance with ANSI B212.15-1994 to install anchors.

Anchors are tested to ACI 355.2 and ICC-ES AC193. Anchors are listed by the following agencies as required by the local building code: ICC-ES, UL, FM, and Caltrans.

See Appendix B (pages 106-107) for performance values in accordance to 2015 IBC.

## ADVANTAGES

- 2015 International Building Code (IBC) Compliant for 1/4" through 1/2" diameters-carbon steel
- Versatile fully threaded design is standard on sizes up to 1" diameter and 10" length
- Anchor diameter equals hole diameter
- Standard carbon and stainless steel anchors
- Non bottom-bearing, may be used in hole depth exceeding anchor length
- Can be installed through the work fixture, eliminating hole spotting
- Inspectable torque values, indicating proper installation

### Fully Threaded Advantage

Trubolt's fully threaded feature eliminates subsurface obstruction problems.

Fully threaded design accommodates various material thicknesses at the same embedment. One anchor length saves time and money.

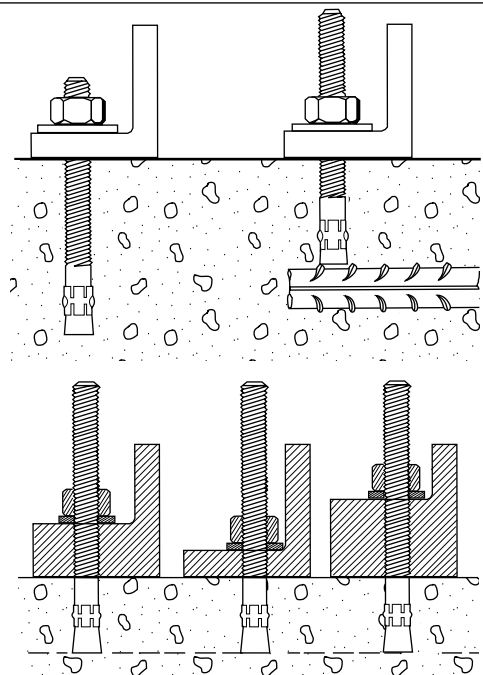

## APPLICATIONS

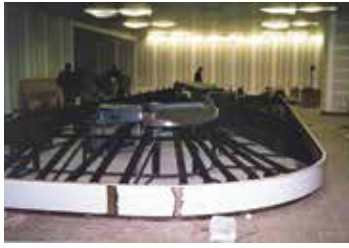

Anchoring machinery and conveyors is a common wedge anchor application. The Trubolt is fully threaded to allow a large range of embedment and fixture thickness.

## LENGTH INDICATION CODE\*

CODE	LENGTH OF ANCHOR	CODE	LENGTH OF ANCHOR
A	1-1/2 < 2 (38.1 < 50.8)	K	6-1/2 < 7 (165.1 < 177.8)
B	2 < 2-1/2 (50.8 < 63.5)	L	7 < 7-1/2 (177.8 < 190.5)
C	2-1/2 < 3 (63.5 < 76.2)	M	7-1/2 < 8 (190.5 < 203.2)
D	3 < 3-1/2 (76.2 < 88.9)	N	8 < 8-1/2 (203.2 < 215.9)
E	3-1/2 < 4 (88.9 < 101.6)	O	8-1/2 < 9 (215.9 < 228.6)
F	4 < 4-1/2 (101.6 < 114.3)	P	9 < 9-1/2 (228.6 < 241.3)
G	4-1/2 < 5 (114.3 < 127.0)	Q	9-1/2 < 10 (241.3 < 254.0)
H	5 < 5-1/2 (127.0 < 139.7)	R	10 < 11 (254.0 < 279.4)
I	5-1/2 < 6 (139.7 < 152.4)	S	11 < 12 (279.4 < 304.8)
J	6 < 6-1/2 (152.4 < 165.1)	T	12 < 13 (304.8 < 330.2)

\*Located on top of anchor for easy inspection.

## FEATURES



**Length ID Head Stamp**—provides for embedment inspection after installation

**Fully Threaded Design**

**Cold-Formed**—manufacturing process adds strength

**Stainless steel split expansion ring**

**Anchor Body**—available in zinc-plated steel, hot-dipped galvanized steel, 304 stainless steel and 316 stainless steel

**TRUBOLT® WEDGE ANCHOR**

## APPROVALS/LISTINGS

### Trubolt®

Wedge Anchors

ICC Evaluation Service, Inc. ESR-2251

- Category 1 performance rating
- 2015 IBC compliant
- Meets ACI 318 ductility requirements
- Tested in accordance with ACI 355.2 and ICC-ES AC193
- For use in seismic zones A & B
- 1/4", 3/8" & 1/2" diameter anchors listed in ESR-2251

Underwriters Laboratories

Factory Mutual

Caltrans

Meets or exceeds U.S. Government G.S.A. Specification A-A-1923A Type 4 (formerly GSA: FF-S-325 Group II, Type 4, Class 1)

Made in USA



## INSTALLATION STEPS

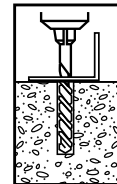

1. Select a carbide drill bit with a diameter equal to the anchor diameter. Drill hole to any depth exceeding the desired embedment. See chart for minimum recommended embedment.

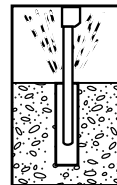

2. Clean hole or continue drilling additional depth to accommodate drill fines.



3. Assemble washer and nut, leaving top of stud exposed through nut. Drive anchor through material to be fastened until washer is flush to surface of material.



4. Expand anchor by tightening nut 3-5 turns past the hand tight position, or to the specified torque requirement.

**\*\* ONLY FOR USE IN CONCRETE\*\***



## SELECTION CHARTS

### Trubolt Carbon Steel with Zinc Plating

Meets ASTM B633 SC1, Type III specifications for electroplating of 5um = .0002" thickness.  
This material is well suited for non-corrosive environments.



**Typical Applications**—  
Structural Columns,  
Machinery, Equipment, etc.  
**Environment**—Interior  
(non-corrosive)  
**Level of Corrosion**—Low

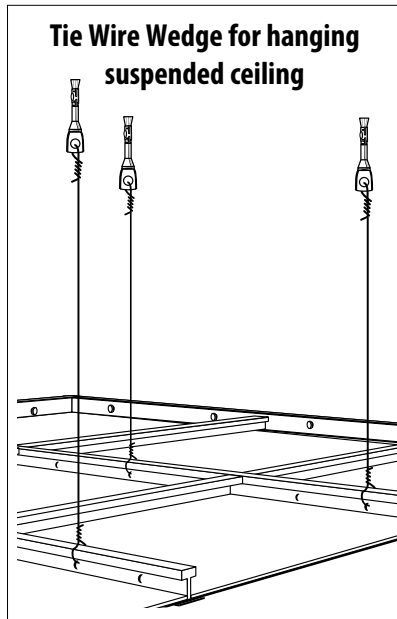

PART NUMBER	THREAD LENGTH In. (mm)	ANCHOR DIA. & DRILL BIT SIZE (THREADS) PER INCH	OVERALL LENGTH In. (mm)	MAX. THICKNESS OF MATERIAL TO BE FASTENED In. (mm)	QTY/WT PER BOX lbs.	QTY/WT PER MASTER CARTON lbs.
WS-1416	3/4 (19.1)	1/4" - 20	1-3/4 (44.5)	3/8 (9.5)	100/ 3.1	1000/ 32
WS-1422	1-1/4 (31.8)		2-1/4 (57.2)	7/8 (22.2)	100/ 3.6	1000/ 37
WS-1432	2-1/4 (57.2)		3-1/4 (82.6)	1-7/8 (47.6)	100/ 4.7	800/ 39
WS-3822	1-1/8 (28.6)	3/8" - 16	2-1/4 (57.2)	3/8 (9.5)	50/ 4.1	500/ 41
WS-3826	1-5/8 (41.3)		2-3/4 (69.9)	7/8 (22.2)	50/ 4.7	400/ 39
WS-3830	1-3/4 (44.5)		3 (76.2)	1-1/8 (28.6)	50/ 5.0	400/ 41
WS-3836	2-1/2 (63.5)		3-3/4 (95.3)	1-7/8 (47.6)	50/ 5.9	300/ 36
WS-3850	3-3/4 (95.2)		5 (127.0)	3-1/8 (79.4)	50/ 7.4	250/ 38
WS-3870	3-7/8 (98.4)		7 (177.8)	5-1/8 (130.2)	50/ 10.4	250/ 53
WS-1226	1-1/4 (31.8)	1/2" - 13	2-3/4 (69.9)	1/8 (3.2)	25/ 4.6	200/ 38
WS-1236	2-1/4 (57.2)		3-3/4 (95.3)	1 (25.4)	25/ 5.7	150/ 35
WS-1242	2-3/4 (69.9)		4-1/4 (108.0)	1-1/2 (38.1)	25/ 6.2	150/ 38
WS-1244	3 (76.2)		4-1/2 (114.3)	1-3/4 (44.5)	25/ 6.5	150/ 39
WS-1254	4 (101.6)		5-1/2 (139.7)	2-3/4 (69.9)	25/ 7.7	150/ 47
WS-1270	5-1/2 (139.7)		7 (177.8)	4-1/4 (108.0)	25/ 9.3	150/ 57
WS-5834	1-3/4 (44.5)	5/8" - 11	3-1/2 (88.9)	1/8 (3.2)	10/ 3.6	100/ 37
WS-5842	2-1/2 (63.5)		4-1/4 (108.0)	7/8 (22.2)	10/ 4.1	100/ 42
WS-5850	3-1/4 (82.6)		5 (127.0)	1-5/8 (41.3)	10/ 4.7	100/ 48
WS-5860	4-1/4 (107.9)		6 (152.4)	2-5/8 (66.7)	10/ 5.4	50/ 28
WS-5870	5-1/4 (133.4)		7 (177.8)	3-5/8 (92.1)	10/ 6.2	30/ 19
WS-5884	5-3/4 (146.0)		8-1/2 (215.9)	5-1/8 (130.2)	10/ 8.0	30/ 25
WS-58100	5-3/4 (146.0)		10 (254.0)	6-5/8 (168.3)	10/ 9.4	30/ 29
WS-3442	2-3/8 (60.3)	3/4" - 10	4-1/4 (108.0)	1/4 (31.8)	10/ 6.8	60/ 42
WS-3446	2-7/8 (73.0)		4-3/4 (120.7)	3/4 (19.1)	10/ 7.4	60/ 45
WS-3454	3-5/8 (92.1)		5-1/2 (139.7)	1-1/2 (38.1)	10/ 8.1	50/ 41
WS-3462	4-3/8 (111.1)		6-1/4 (158.8)	2-1/4 (57.2)	10/ 9.1	30/ 28
WS-3470	5-1/8 (130.2)		7 (177.8)	3 (76.2)	10/ 9.7	30/ 30
WS-3484	5-3/4 (146.0)		8-1/2 (215.9)	4-1/2 (114.3)	10/ 12.3	30/ 38
WS-34100	5-3/4 (146.0)		10 (254.0)	6 (152.4)	10/ 14.0	30/ 43
WS-34120	1-3/4 (44.5)		12 (304.8)	8 (203.2)	10/ 16.6	30/ 51
WS-7860	2-1/2 (63.5)	7/8" - 9	6 (152.4)	1-3/8 (34.9)	5/ 6.3	25/ 32
WS-7880	2-1/2 (63.5)		8 (203.2)	3-3/8 (85.7)	5/ 8.1	15/ 25
WS-78100	2-1/2 (63.5)		10 (254.0)	5-3/8 (136.5)	5/ 9.8	15/ 30
WS-10060	2-1/2 (63.5)	1" - 8	6 (152.4)	1/2 (12.7)	5/ 8.3	25/ 43
WS-10090	2-1/2 (63.5)		9 (228.6)	3-1/2 (88.9)	5/ 11.6	15/ 36
WS-100120	2-1/2 (63.5)		12 (304.8)	6-1/2 (165.1)	5/ 15.0	15/ 46
<b>TIE WIRE</b>						
TW-1400	N/A	1/4"	2-1/8 (54.0)	9/32-hole (7.1)	100/ 3.6	1000/ 36
TW-1400 K	N/A		2-1/8 (54.0)	9/32-hole (7.1)	BULK	1500/ 73

## SELECTION CHARTS

### Trubolt Carbon Steel with Hot-Dipped Galvanizing

Meets ASTM A153 Class specifications for hot-dipped galvanizing > 45um = .002". It is highly recommended for damp, humid environments near coastal regions. Hot-dipped galvanized Trubolts have a coating thickness of zinc that is almost 10 times as thick as electroplating. This creates greater corrosion resistance at a minimal cost.



**Typical Applications**—  
Railings, Signage, Awnings, etc.  
**Environment**—Rural/  
Suburban (exterior environ-  
ment—  
essentially unpolluted areas)  
**Level of Corrosion**—  
Low to Medium

PART NUMBER	THREAD LENGTH In. (mm)	ANCHOR DIA. & DRILL BIT SIZE (THREADS) PER INCH	OVERALL LENGTH In. (mm)	MAX. THICKNESS OF MATERIAL TO BE FASTENED In. (mm)	QTY/WT PER BOX lbs.	QTY/WT PER MASTER CARTON lbs.
WS-1226G	1-1/4 (31.8)	1/2" - 13	2-3/4 (69.9)	1/8 (3.2)	25/ 4.8	200/ 39
WS-1242G	2-3/4 (69.9)		4-1/4 (108.0)	1-1/2 (38.1)	25/ 6.7	150/ 41
WS-1254G	4 (101.6)		5-1/2 (139.7)	2-3/4 (69.9)	25/ 8.0	150/ 49
WS-1270G	5-1/2 (139.7)		7 (177.8)	4-1/4 (108.0)	25/ 9.7	150/ 59
WS-5834G	1-3/4 (44.5)	5/8" - 11	3-1/2 (88.9)	1/8 (3.2)	10/ 3.7	100/ 38
WS-5860G	4-1/4 (107.9)		6 (152.4)	2-5/8 (66.7)	10/ 5.6	50/ 29
WS-3446G	2-7/8 (73.0)	3/4" - 10	4-3/4 (120.7)	3/4 (19.1)	10/ 7.5	60/ 46
WS-3454G	3-5/8 (92.1)		5-1/2 (139.7)	1-1/2 (38.1)	10/ 8.4	50/ 42
WS-3484G	5-3/4 (146.0)		8-1/2 (215.9)	4-1/2 (114.3)	10/ 12.5	30/ 38

## SELECTION CHARTS

# Trubolt Type 304 Stainless Steel

Serves many applications well. It withstands rusting in architectural and food processing environments and resists organic chemicals, dye stuffs and many inorganic chemicals.



**Typical Applications—**  
Cladding, Stadium Seating, etc.

**Environment—**Urban  
(slight to moderate  
degree of pollution)

**Level of Corrosion—**Medium

PART NUMBER	THREAD LENGTH In. (mm)	ANCHOR DIA. & DRILL BIT SIZE (THREADS) PER INCH	OVERALL LENGTH In. (mm)	MAX. THICKNESS OF MATERIAL TO BE FASTENED In. (mm)	QTY/WT PER BOX lbs.	QTY/WT PER MASTER CARTON lbs.
WW-1416	3/4 (19.1)	1/4" - 20	1-3/4 (44.5)	3/8 (9.5)	100/ 3.2	1000/ 32
WW-1422	1-1/4 (31.8)		2-1/4 (57.2)	7/8 (22.2)	100/ 3.7	1000/ 37
WW-1432	2-1/4 (57.2)		3-1/4 (82.6)	1-7/8 (47.6)	100/ 4.8	800/ 39
WW-3822	1-1/8 (28.6)	3/8" - 16	2-1/4 (57.2)	3/8 (9.5)	50/ 4.1	500/ 41
WW-3826	1-5/8 (41.3)		2-3/4 (69.9)	7/8 (22.2)	50/ 4.8	400/ 39
WW-3830	1-3/4 (44.5)		3 (76.2)	1-1/8 (28.6)	50/ 5.1	400/ 42
WW-3836	2-1/2 (63.5)		3-3/4 (95.3)	1-7/8 (47.6)	50/ 6.0	300/ 37
WW-3850	3-3/4 (95.3)		5 (127.0)	3-1/8 (79.4)	50/ 7.5	250/ 39
WW-1226	1-1/4 (31.8)	1/2" - 13	2-3/4 (69.9)	1/8 (3.2)	25/ 4.7	200/ 38
WW-1236	2-1/4 (57.2)		3-3/4 (95.3)	1 (25.4)	25/ 5.8	150/ 36
WW-1242	2-3/4 (69.9)		4-1/4 (108.0)	1-1/2 (38.1)	25/ 6.3	150/ 39
WW-1254	3 (76.2)		5-1/2 (139.7)	2-3/4 (69.9)	25/ 7.7	150/ 47
WW-1270	3-1/2 (88.9)		7 (177.8)	4-1/4 (108.0)	25/ 9.4	150/ 57
WW-5834	1-3/4 (44.5)	5/8" - 11	3-1/2 (88.9)	1/8 (3.2)	10/ 3.6	100/ 37
WW-5842	2-1/2 (63.5)		4-1/4 (108.0)	7/8 (22.2)	10/ 4.2	100/ 43
WW-5850	3-1/4 (82.6)		5 (127.0)	1-5/8 (41.3)	10/ 4.8	100/ 49
WW-5860	4-1/4 (107.9)		6 (152.4)	2-5/8 (66.7)	10/ 5.5	50/ 28
WW-5870	3-1/2 (88.9)		7 (177.8)	3-5/8 (92.1)	10/ 6.2	30/ 20
WW-5884	3-1/2 (88.9)		8-1/2 (215.9)	5-1/8 (130.2)	10/ 8.0	30/ 25
WW-3446	2-7/8 (73.0)	3/4" - 10	4-3/4 (120.7)	3/4 (19.1)	10/ 6.7	60/ 41
WW-3454	3-5/8 (92.1)		5-1/2 (139.7)	1-1/2 (38.1)	10/ 7.5	50/ 38
WW-3470	3-1/2 (88.9)		7 (177.8)	3 (76.2)	10/ 9.2	30/ 28
WW-3484	3-1/2 (88.9)		8-1/2 (215.9)	4-1/2 (114.3)	10/ 12.3	30/ 38
WW-34100	1-3/4 (44.5)		10 (254.0)	6 (152.4)	10/ 13.5	30/ 42
WW-10060	2-1/2 (63.5)	1" - 8	6 (152.4)	1/2 (12.7)	5/ 8.3	25/ 43
WW-10090	2-1/2 (63.5)		9 (228.6)	3-1/2 (88.9)	5/ 11.4	15/ 35

\* For continuous extreme low temperature applications, use stainless steel.

## SELECTION CHARTS

# Trubolt Type 316 Stainless Steel

Contains more nickel and chromium than Type 304, and 2%-3% molybdenum, which gives it better corrosion resistance. It is especially more effective in chloride environments that tend to cause pitting.



**Typical Applications—**  
Pumps, Diffusers, Gates,  
Weir Plates, etc.

**Environment—**Industrial  
(moderate to heavy  
atmospheric pollution)

**Level of Corrosion—**  
Medium to High



**Typical Applications—**  
Tunnels, Dams, Tiles,  
Lighting Fixtures, etc.

**Environment—**  
Marine (heavy atmospheric  
pollution)

**Level of Corrosion—**High

PART NUMBER	THREAD LENGTH In. (mm)	ANCHOR DIA. & DRILL BIT SIZE (THREADS) PER INCH	OVERALL LENGTH In. (mm)	MAX. THICKNESS OF MATERIAL TO BE FASTENED In. (mm)	QTY/WT PER BOX lbs.	QTY/WT PER MASTER CARTON lbs.
SWW-1422	1-1/4 (31.8)	1/4" - 20	2-1/4 (57.2)	7/8 (22.2)	100/ 3.7	1000/ 37
SWW-1432	2-1/4 (57.2)		3-1/4 (82.6)	1-1/8 (28.6)	100/ 4.8	1000/ 39
SWW-3822	1-1/8 (28.6)	3/8" - 16	2-1/4 (57.2)	3/8 (9.5)	50/ 4.1	500/ 41
SWW-3826	1-5/8 (41.3)		2-3/4 (69.9)	7/8 (22.2)	50/ 4.8	400/ 39
SWW-3830	1-3/4 (44.5)		3 (76.2)	1-1/8 (28.6)	50/ 5.2	400/ 42
SWW-3836	2-1/2 (63.5)		3-3/4 (95.3)	1-7/8 (47.6)	50/ 6.0	300/ 37
SWW-3850	3-3/4 (95.3)		5 (127.0)	3-1/8 (79.4)	50/ 7.5	250/ 39
SWW-1226	1-1/4 (31.8)	1/2" - 13	2-3/4 (69.9)	1/8 (3.2)	25/ 4.7	200/ 39
SWW-1236	2-1/4 (57.2)		3-3/4 (95.3)	1 (25.4)	25/ 5.8	150/ 36
SWW-1242	2-3/4 (69.9)		4-1/4 (108.0)	1-1/2 (38.1)	25/ 6.5	150/ 40
SWW-1254	3 (76.2)		5-1/2 (139.7)	2-3/4 (69.9)	25/ 7.8	150/ 48
SWW-5842	2-1/2 (63.5)	5/8" - 11	4-1/4 (108.0)	7/8 (22.2)	10/ 4.2	100/ 43
SWW-5850	3-1/4 (82.6)		5 (127.0)	1-5/8 (41.3)	10/ 4.8	100/ 49
SWW-5870	3-1/2 (88.9)		7 (177.8)	3-5/8 (92.1)	10/ 6.7	30/ 21

\* For continuous extreme low temperature applications, use stainless steel.



## PERFORMANCE TABLE

# Trubolt Wedge Anchors

## Ultimate Tension and Shear Values (Lbs/kN) in Concrete\*

ANCHOR DIA. In. (mm)	INSTALLATION TORQUE Ft. Lbs. (Nm)	EMBEDMENT DEPTH In. (mm)	ANCHOR TYPE	f'c = 2000 PSI (13.8 MPa)		f'c = 4000 PSI (27.6 MPa)		f'c = 6000 PSI (41.4 MPa)	
				TENSION Lbs. (kN)	SHEAR Lbs. (kN)	TENSION Lbs. (kN)	SHEAR Lbs. (kN)	TENSION Lbs. (kN)	SHEAR Lbs. (kN)
1/4 (6.4)	4 (5.4)	1-1/8 (28.6)	WS-Carbon or WS-G Hot-Dipped Galvanized or WW-304 S.S. or SWW-316 S.S.	1,180 (5.2)	1,400 (6.2)	1,780 (7.9)	1,400 (6.2)	1,900 (8.5)	1,400 (6.2)
		1-15/16 (49.2)		2,100 (9.3)	1,680 (7.5)	3,300 (14.7)	1,680 (7.5)	3,300 (14.7)	1,680 (7.5)
		2-1/8 (54.0)		2,260 (10.1)	1,680 (7.5)	3,300 (14.7)	1,680 (7.5)	3,300 (14.7)	1,680 (7.5)
3/8 (9.5)	25 (33.9)	1-1/2 (38.1)		1,620 (7.5)	2,320 (10.3)	2,240 (10.0)	2,620 (11.7)	2,840 (12.6)	3,160 (14.1)
		3 (76.2)		3,480 (15.5)	4,000 (17.8)	5,940 (26.4)	4,140 (18.4)	6,120 (27.2)	4,500 (20.0)
		4 (101.6)		4,800 (21.4)	4,000 (17.8)	5,940 (26.4)	4,140 (18.4)	6,120 (27.2)	4,500 (20.0)
1/2 (12.7)	55 (74.6)	2-1/4 (57.2)		3,455 (20.7)	4,760 (21.2)	4,920 (22.7)	4,760 (21.2)	6,025 (31.3)	7,040 (31.3)
		4-1/8 (104.8)		4,660 (20.7)	7,240 (32.2)	9,640 (42.9)	7,240 (32.2)	10,820 (48.1)	8,160 (36.3)
		6 (152.4)		5,340 (23.8)	7,240 (32.2)	9,640 (42.9)	7,240 (32.2)	10,820 (48.1)	8,160 (36.3)
5/8 (15.9)	90 (122.0)	2-3/4 (69.9)		5,185 (29.3)	7,120 (31.7)	7,180 (31.9)	7,120 (31.7)	9,225 (43.2)	9,616 (42.8)
		5-1/8 (130.2)		6,580 (29.3)	9,600 (42.7)	14,920 (66.4)	11,900 (52.9)	16,380 (72.9)	12,520 (55.7)
		7-1/2 (190.5)		7,060 (31.4)	9,600 (42.7)	15,020 (66.8)	11,900 (52.9)	16,380 (72.9)	12,520 (55.7)
3/4 (19.1)	110 (149.2)	3-1/4 (82.6)	6,765 (31.7)	10,120 (45.0)	10,840 (48.2)	13,720 (61.0)	13,300 (59.2)	15,980 (71.1)	
		6-5/8 (168.3)	10,980 (48.8)	20,320 (90.4)	17,700 (78.7)	23,740 (105.6)	20,260 (90.1)	23,740 (105.6)	
		10 (254.0)	10,980 (48.8)	20,320 (90.4)	17,880 (79.5)	23,740 (105.6)	23,580 (104.9)	23,740 (105.6)	
7/8 (22.2)	250 (339.0)	3-3/4 (95.3)	9,290 (42.3)	13,160 (58.5)	14,740 (65.6)	16,580 (73.8)	17,420 (77.5)	19,160 (85.2)	
		6-1/4 (158.8)	14,660 (65.2)	20,880 (92.9)	20,940 (93.1)	28,800 (128.1)	24,360 (108.4)	28,800 (128.1)	
		8 (203.2)	14,660 (65.2)	20,880 (92.9)	20,940 (93.1)	28,800 (128.1)	24,360 (108.4)	28,800 (128.1)	
1 (25.4)	300 (406.7)	4-1/2 (114.3)	11,770 (62.0)	16,080 (71.5)	19,245 (89.8)	22,820 (101.5)	21,180 (94.2)	24,480 (108.9)	
		7-3/8 (187.3)	14,600 (64.9)	28,680 (127.6)	23,980 (106.7)	37,940 (168.8)	33,260 (148.0)	38,080 (169.4)	
		9-1/2 (241.3)	18,700 (83.2)	28,680 (127.6)	26,540 (118.1)	37,940 (168.8)	33,260 (148.0)	38,080 (169.4)	

\* Allowable values are based upon a 4 to 1 safety factor. Divide by 4 for allowable load values.

\* For Tie-Wire Wedge Anchor, TW-1400, use tension data from 1/4" diameter with 1-1/8" embedment.

\* For continuous extreme low temperature applications, use stainless steel.

## PERFORMANCE TABLE

# Trubolt Wedge Anchors

## Ultimate Tension and Shear Values (Lbs/kN) in Lightweight Concrete\*

ANCHOR DIA. In. (mm)	INSTALLATION TORQUE Ft. Lbs. (Nm)	EMBEDMENT DEPTH In. (mm)	ANCHOR TYPE	LIGHTWEIGHT CONCRETE f'c = 3000 PSI (20.7 MPa)		LOWER FLUTE OF STEEL DECK WITH LIGHTWEIGHT CONCRETE FILL f'c = 3000 PSI (20.7 MPa)	
				TENSION Lbs. (kN)	SHEAR Lbs. (kN)	TENSION Lbs. (kN)	SHEAR Lbs. (kN)
3/8 (9.5)	25 (33.9)	1-1/2 (38.1)	WS-Carbon or WS-G Hot-Dipped Galvanized or WW-304 S.S. or SWW-316 S.S.	1,175 (5.2)	1,480 (6.6)	1,900 (8.5)	3,160 (14.1)
		3 (76.2)		2,825 (12.6)	2,440 (10.9)	2,840 (12.6)	4,000 (17.8)
1/2 (12.7)	55 (74.6)	2-1/4 (57.2)		2,925 (13.0)	2,855 (12.7)	3,400 (15.1)	5,380 (23.9)
		3 (76.2)		3,470 (15.4)	3,450 (15.3)	4,480 (19.9)	6,620 (29.4)
5/8 (15.9)	90 (122.0)	4 (101.6)		4,290 (19.1)	3,450 (15.3)	4,800 (21.4)	6,440 (28.6)
		3 (76.2)		4,375 (19.5)	4,360 (19.4)	4,720 (21.0)	5,500 (24.5)
3/4 (19.1)	110 (149.2)	5 (127.0)		6,350 (28.2)	6,335 (28.2)	6,580 (29.3)	9,140 (40.7)
		5-1/4 (133.4)		5,390 (24.0)	7,150 (31.8)	5,840 (26.0)	8,880 (39.5)
				7,295 (32.5)	10,750 (47.8)	7,040 (31.3)	N/A

\* Allowable values are based upon a 4 to 1 safety factor. Divide by 4 for allowable load values.

**PERFORMANCE TABLE**

**Trubolt** *Recommended Edge and Spacing Distance Requirements for Shear Loads\**  
**Wedge Anchors**

ANCHOR DIA. In. (mm)	EMBEDMENT DEPTH In. (mm)	ANCHOR TYPE	EDGE DISTANCE REQUIRED TO OBTAIN MAX. WORKING LOAD In. (mm)	MIN. EDGE DISTANCE AT WHICH THE LOAD FACTOR APPLIED = .60 In. (mm)	MIN. EDGE DISTANCE AT WHICH THE LOAD FACTOR APPLIED = .20 In. (mm)	SPACING REQUIRED TO OBTAIN MAX. WORKING LOAD In. (mm)	MIN. ALLOWABLE SPACING BETWEEN ANCHORS In. (mm) LOAD FACTOR APPLIED = .40
1/4 (6.4)	1-1/8 (28.6)	WS-Carbon or WS-G Hot-Dipped Galvanized or WW-304 S.S. or SWW-316 S.S.	2 (50.8)	1-5/16 (33.3)	N/A	3-15/16 (100.0)	2 (50.8)
	1-15/16 (49.2)		1 (25.4)	N/A	3-7/8 (98.4)	1-15/16 (49.2)	
3/8 (9.5)	1-1/2 (38.1)		2-5/8 (66.7)	1-3/4 (44.5)	N/A	5-1/4 (133.4)	2-5/8 (66.7)
	3 (76.2)		3-3/4 (95.3)	3 (76.2)	1-1/2 (38.1)	6 (152.4)	3 (76.2)
1/2 (12.7)	2-1/4 (57.2)		3-15/16 (100.0)	2-9/16 (65.1)	N/A	7-7/8 (200.0)	3-15/16 (100.0)
	4-1/8 (104.8)		5-3/16 (131.8)	3-1/8 (79.4)	1-9/16 (39.7)	6-3/16 (157.2)	3-1/8 (79.4)
5/8 (15.9)	2-3/4 (69.9)		4-13/16 (122.2)	3-1/8 (79.4)	N/A	9-5/8 (244.5)	4-13/16 (122.2)
	5-1/8 (130.2)		6-7/16 (163.5)	3-7/8 (98.4)	1-15/16 (49.2)	7-11/16 (195.3)	3-7/8 (98.4)
3/4 (19.1)	3-1/4 (82.6)		5-11/16 (144.5)	3-3/4 (95.3)	N/A	11-3/8 (288.9)	5-11/16 (144.5)
	6-5/8 (168.3)		6-5/16 (160.3)	5 (127.0)	2-1/2 (63.5)	9-15/16 (252.4)	5 (127.0)
7/8 (22.2)	3-3/4 (95.3)	6-9/16 (166.7)	4-5/16 (109.5)	N/A	13-1/8 (333.4)	6-9/16 (166.7)	
	6-1/4 (158.8)	8-1/2 (215.9)	6-1/4 (158.8)	3-1/8 (79.4)	12-1/2 (317.5)	6-1/4 (158.8)	
1 (25.4)	4-1/4 (108.0)	7-7/8 (200.0)	5-1/8 (130.2)	N/A	15-3/4 (400.1)	7-7/8 (200.0)	
	7-3/8 (187.3)	10-1/16 (255.6)	7-3/8 (187.3)	3-11/16 (93.7)	14-3/4 (374.7)	7-3/8 (187.3)	

\* Spacing and edge distances shall be divided by 0.75 when anchors are placed in structural lightweight concrete. Linear interpolation may be used for intermediate spacing and edge distances.

**PERFORMANCE TABLE**

**Trubolt** *Recommended Edge and Spacing Distance Requirements for Tension Loads\**  
**Wedge Anchors**

ANCHOR DIA. In. (mm)	EMBEDMENT DEPTH In. (mm)	ANCHOR TYPE	EDGE DISTANCE REQUIRED TO OBTAIN MAX. WORKING LOAD In. (mm)	MIN. ALLOWABLE EDGE DISTANCE AT WHICH THE LOAD FACTOR APPLIED = .65 In. (mm)	SPACING REQUIRED TO OBTAIN MAX. WORKING LOAD In. (mm)	MIN. ALLOWABLE SPACING AT WHICH THE LOAD FACTOR APPLIED = .70 In. (mm)
1/4 (6.4)	1-1/8 (28.6)	WS-Carbon or WS-G Hot-Dipped Galvanized or WW-304 S.S. or SWW-316 S.S.	2 (50.8)	1 (25.4)	3-15/16 (100.0)	2 (50.8)
	1-15/16 (49.2)		1 (25.4)	3-7/8 (98.4)	1-15/16 (49.2)	
	2-1/8 (54.0)		13/16 (20.6)	3-3/16 (81.0)	1-5/8 (41.3)	
3/8 (9.5)	1-1/2 (38.1)		2-5/8 (66.7)	1-5/16 (33.3)	5-1/4 (133.4)	2-5/8 (66.7)
	3 (76.2)		3 (76.2)	1-1/2 (38.1)	6 (152.4)	3 (76.2)
	4 (101.6)		3 (76.2)	1-1/2 (38.1)	6 (152.4)	3 (76.2)
1/2 (12.7)	2-1/4 (57.2)		3-15/16 (100.0)	2 (50.8)	7-7/8 (200.0)	3-15/16 (100.0)
	4-1/8 (104.8)		3-1/8 (79.4)	1-9/16 (39.7)	6-3/16 (157.2)	3-1/8 (79.4)
	6 (152.4)		4-1/2 (114.3)	2-1/4 (57.2)	9 (228.6)	4-1/2 (114.3)
5/8 (15.9)	2-3/4 (69.9)		4-13/16 (122.2)	2-7/16 (61.9)	9-5/8 (244.5)	4-13/16 (122.2)
	5-1/8 (130.2)	3-7/8 (98.4)	1-15/16 (49.2)	7-1/16 (195.3)	3-7/8 (98.4)	
	7-1/2 (190.5)	5-5/8 (142.9)	2-13/16 (71.4)	11-1/4 (285.8)	5-5/8 (142.9)	
3/4 (19.1)	3-1/4 (82.6)	5-11/16 (144.5)	2-7/8 (73.0)	11-3/8 (288.9)	5-11/16 (144.5)	
	6-5/8 (168.3)	5 (127.0)	2-1/2 (63.5)	9-15/16 (252.4)	5 (127.0)	
	10 (254.0)	7-1/2 (190.5)	3-3/4 (95.3)	15 (381.0)	7-1/2 (190.5)	
7/8 (22.2)	3-3/4 (95.3)	6-9/16 (166.7)	3-5/16 (84.1)	13-1/8 (333.4)	6-9/16 (166.7)	
	6-1/4 (158.8)	6-1/4 (158.8)	3-1/8 (79.4)	12-1/2 (317.5)	6-1/4 (158.8)	
	8 (203.2)	6 (152.4)	3 (76.2)	12 (304.8)	6 (152.4)	
1 (25.4)	4-1/2 (114.3)	7-7/8 (200.0)	3-15/16 (100.0)	15-3/4 (400.1)	7-7/8 (200.0)	
	7-3/8 (187.3)	7-3/8 (187.3)	3-11/16 (93.7)	14-3/4 (374.7)	7-3/8 (187.3)	
	9-1/2 (241.3)	7-1/8 (181.0)	3-9/16 (90.5)	14-1/4 (362.0)	7-1/8 (181.0)	

\* Spacing and edge distances shall be divided by 0.75 when anchors are placed in structural lightweight concrete. Linear interpolation may be used for intermediate spacing and edge distances.

**Combined Tension and Shear Loading—for Trubolt Anchors**

Allowable loads for anchors subjected to combined shear and tension forces are determined by the following equation:

$$(P_s/P_t)^{5/3} + (V_s/V_t)^{5/3} \leq 1$$

$P_s$  = Applied tension load     $V_s$  = Applied shear load     $P_t$  = Allowable tension load     $V_t$  = Allowable shear load

# Trubolt<sup>®</sup> + Seismic Wedge Anchors



**2015 IBC  
Compliant**

## DESCRIPTION/SUGGESTED SPECIFICATIONS

### Seismic Wedge Type Anchors—

Trubolt+ Wedge anchors consist of a high-strength threaded stud body, expansion clip, nut and washer. Anchor bodies are made of plated carbon steel. The expansion clip consists of a split cylindrical ring with undercutting grooves.

The exposed end of the anchor is stamped to identify anchor length. Stampings should be preserved during installation for any subsequent embedment verification.

Use carbide tipped hammer drill bits made in accordance with ANSI B212.15-1994 to install anchors.

Anchors are tested to ACI 355.2 and ICC-ES AC193. Anchors are listed by the following agencies as required by the local building code: ICC-ES, and City of Los Angeles.

See Appendix C (pages 108-109) for performance values in accordance with 2015 IBC.

## INSTALLATION STEPS

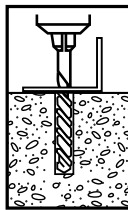

**1.** Select a carbide drill bit with a diameter equal to the anchor diameter. Drill hole to any depth exceeding the desired embedment. See chart for minimum recommended embedment.

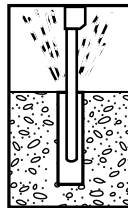

**2.** Clean hole or continue drilling additional depth to accommodate drill fines



**3.** Assemble washer and nut, leaving top of stud exposed through nut. Drive anchor through material to be fastened until washer is flush to surface of material.



**4.** Expand anchor by tightening nut 3-5 turns past the hand tight position, or to the specified torque requirement.

## APPROVALS/LISTINGS

- ICC Evaluation Service, Inc. # ESR-2427
- Category 1 performance rating
- 2015 IBC Compliant
- Meets ACI 318 ductility requirements
- Tested in accordance with ACI 355.2 and ICC-ES AC193
- Listed for use in seismic zones A, B, C, D, E, & F
- 3/8", 1/2", 5/8" and 3/4" diameter anchors listed in ESR-2427

City of Los Angeles - #RR25867  
Florida Building Code

## SELECTION CHART

**Trubolt<sup>®</sup> +** Meets ASTM B633 SC1, Type III specifications for electroplating of 5um = .0002" thickness. This coating is well suited for non-corrosive environments.  
Seismic Wedge Anchors  
**Carbon Steel with Zinc Plating**

PART NUMBER	THREAD LENGTH In. (mm)	ANCHOR DIA. & DRILL BIT SIZE (THREADS) PER INCH	OVERALL LENGTH In. (mm)	MAX. THICKNESS OF MATERIAL TO BE FASTENED In. (mm)	QTY/WT PER BOX lbs.	QTY/WT PER MASTER CARTON lbs.
CWS-3830	1-5/8 (41.3)	3/8" - 16	3 (76.2)	5/8 (15.9)	50/ 5.3	400/ 42
CWS-3836	2-3/8 (60.3)	3/8" - 16	3-3/4 (95.3)	1-3/8 (34.9)	50/ 5.9	300/ 35
CWS-3850	3-5/8 (92.1)	3/8" - 16	5 (127.0)	2-5/8 (66.7)	50/ 7.3	250/ 37
CWS-1236	2-1/8 (54.0)	1/2" - 13	3-3/4 (95.3)	3/4 (19.1)	25/ 5.7	150/ 34
CWS-1244	2-7/8 (73.0)	1/2" - 13	4-1/2 (114.3)	1-1/2 (38.1)	25/ 7.0	150/ 40
CWS-1254	3-7/8 (98.4)	1/2" - 13	5-1/2 (139.7)	2-1/2 (63.5)	25/ 8.0	150/ 49
CWS-1270	5-3/8 (136.5)	1/2" - 13	7 (177.8)	4 (101.6)	25/ 9.2	150/ 55
CWS-5850	3-3/16 (81.0)	5/8" - 11	5 (127.0)	1-1/8 (28.6)	10/ 4.7	100/ 48
CWS-5860	4-3/16 (106.4)	5/8" - 11	6 (152.4)	2-1/8 (54.0)	10/ 5.4	50/ 28
CWS-5870	5-3/16 (131.8)	5/8" - 11	7 (177.8)	3-1/8 (79.4)	10/ 6.2	30/ 19
CWS-5884	5-3/4 (146.0)	5/8" - 11	8-1/2 (215.9)	4-5/8 (117.5)	10/ 8.0	30/ 25
CWS-3454	3-5/8 (92.1)	3/4" - 10	5-1/2 (139.7)	1-1/2 (38.1)	50/ 7.6	30/ 38
CWS-3462	4-3/8 (111.1)	3/4" - 10	6-1/4 (158.8)	2-1/4 (57.2)	10/ 8.5	30/ 26
CWS-3470	5-1/8 (130.2)	3/4" - 10	7 (177.8)	3 (76.2)	10/ 9.0	30/ 27
CWS-3484	5-3/4 (146.0)	3/4" - 10	8-1/2 (215.9)	4-1/2 (114.3)	10/10.5	30/ 32
CWS-34100	5-3/4 (146.0)	3/4" - 10	10 (254.0)	6 (152.4)	10/11.9	30/ 36

## LENGTH INDICATION CODE\*

CODE	LENGTH OF ANCHOR	CODE	LENGTH OF ANCHOR
A	1-1/2 < 2 (38.1 < 50.8)	K	6-1/2 < 7 (165.1 < 177.8)
B	2 < 2-1/2 (50.8 < 63.5)	L	7 < 7-1/2 (177.8 < 190.5)
C	2-1/2 < 3 (63.5 < 76.2)	M	7-1/2 < 8 (190.5 < 203.2)
D	3 < 3-1/2 (76.2 < 88.9)	N	8 < 8-1/2 (203.2 < 215.9)
E	3-1/2 < 4 (88.9 < 101.6)	O	8-1/2 < 9 (215.9 < 228.6)
F	4 < 4-1/2 (101.6 < 114.3)	P	9 < 9-1/2 (228.6 < 241.3)
G	4-1/2 < 5 (114.3 < 127.0)	Q	9-1/2 < 10 (241.3 < 254.0)
H	5 < 5-1/2 (127.0 < 139.7)	R	10 < 11 (254.0 < 279.4)
I	5-1/2 < 6 (139.7 < 152.4)	S	11 < 12 (279.4 < 304.8)
J	6 < 6-1/2 (152.4 < 165.1)	T	12 < 13 (304.8 < 330.2)

\*Located on top of anchor for easy inspection.

# Trubolt<sup>+</sup>

## 316 Stainless Steel



**2015 IBC  
Compliant**

## DESCRIPTION/SUGGESTED SPECIFICATIONS

### Seismic Wedge Type Anchors—

The Trubolt+ Wedge Anchor consists of a high-strength threaded anchor body, expansion clip, hex nut and washer. The anchor body is cold-formed from AISI Type 316 stainless steel materials. The expansion clip is fabricated from Type 316 stainless steel materials. The expansion clip consists of a split cylindrical ring with under cutting grooves at the bottom end.

The exposed end of the anchor is stamped to identify anchor length. Stampings should be preserved during installation for any subsequent embedment verification.

Use carbide tipped hammer drill bits made in accordance with ANSI B212.15-1994 to install anchors.

Anchors are tested to ACI 355.2 and ICC-ES AC193. Anchors are listed by the following agencies as required by the local building code: ICC-ES, and City of Los Angeles.

See Appendix C (page 110) for performance values in accordance with 2015 IBC.

## INSTALLATION STEPS

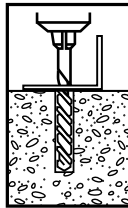

**1.** Select a carbide drill bit with a diameter equal to the anchor diameter. Drill hole to any depth exceeding the desired embedment. See chart for minimum recommended embedment.

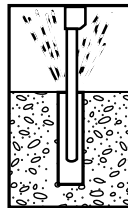

**2.** Clean hole or continue drilling additional depth to accommodate drill fines.

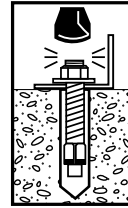

**3.** Assemble washer and nut, leaving top of stud exposed through nut. Drive anchor through material to be fastened until washer is flush to surface of material.



**4.** Expand anchor by tightening nut 3-5 turns past the hand tight position, or to the specified torque requirement.

## APPROVALS/LISTINGS

ICC Evaluation Service, Inc. #ESR-2427

- Category 1 performance rating

- 2015 IBC Compliant

- Meets ACI 318 ductility requirements

- Tested in accordance with ACI 355.2 and ICC-ES AC193

- Listed for use in Seismic zones A, B, C, D, E & F

- 1/2" and 5/8" diameter anchors listed in ESR-2427

City of Los Angeles - #RR25867

## LENGTH INDICATION CODE\*

CODE	LENGTH OF ANCHOR	CODE	LENGTH OF ANCHOR
A	1-1/2 < 2 (38.1 < 50.8)	K	6-1/2 < 7 (165.1 < 177.8)
B	2 < 2-1/2 (50.8 < 63.5)	L	7 < 7-1/2 (177.8 < 190.5)
C	2-1/2 < 3 (63.5 < 76.2)	M	7-1/2 < 8 (190.5 < 203.2)
D	3 < 3-1/2 (76.2 < 88.9)	N	8 < 8-1/2 (203.2 < 215.9)
E	3-1/2 < 4 (88.9 < 101.6)	O	8-1/2 < 9 (215.9 < 228.6)
F	4 < 4-1/2 (101.6 < 114.3)	P	9 < 9-1/2 (228.6 < 241.3)
G	4-1/2 < 5 (114.3 < 127.0)	Q	9-1/2 < 10 (241.3 < 254.0)
H	5 < 5-1/2 (127.0 < 139.7)	R	10 < 11 (254.0 < 279.4)
I	5-1/2 < 6 (139.7 < 152.4)	S	11 < 12 (279.4 < 304.8)
J	6 < 6-1/2 (152.4 < 165.1)	T	12 < 13 (304.8 < 330.2)

\*Located on top of anchor for easy inspection.

## SELECTION CHART

**Trubolt<sup>+</sup>**  
Seismic Wedge Anchors

**316 Stainless Steel**

Meets ASTM B633 SC1, Type III specifications for electroplating of 5um = .0002" thickness. This coating is well suited for non-corrosive environments.

PART NUMBER	THREAD LENGTH In. (mm)	ANCHOR DIA. & DRILL BIT SIZE (THREADS) PER INCH	OVERALL LENGTH In. (mm)	MAX. THICKNESS OF MATERIAL TO BE FASTENED In. (mm)	QTY/WT PER BOX lbs.	QTY/WT PER MASTER CARTON lbs.
CSWW-1236	2-1/8 (54.0)	1/2"-13	3-3/4 (95.3)	3/4 (19.1)	25/5.8	150/35
CSWW-1244	2-7/8 (73.0)	1/2"-13	4-1/2 (114.3)	1-1/2 (38.1)	25/6.6	150/40
CSWW-1254	3-7/8 (98.4)	1/2"-13	5-1/2 (139.7)	2-1/2 (63.5)	25/7.9	150/48
CSWW-1270	5-3/8 (136.5)	1/2"-13	7 (177.8)	4 (101.6)	25/9.5	150/57
CSWW-5842	2-7/16 (61.9)	5/8"-11	4-1/2 (114.3)	3/8 (9.5)	10/4.2	100/42
CSWW-5850	3-3/16 (81.0)	5/8"-11	5 (127.0)	1-1/8 (28.6)	10/4.8	100/48

# Large Diameter Tapcon (LDT) Anchors

**Finished head, Removable Anchor**



LDT

(3/8" & 1/2")

(5/8" & 3/4")

Sawtooth™

3/8" and 1/2" are available with **EnvireX** coating

Uses standard drill bits—no special drill bits to purchase or lose!

## DESCRIPTION/SUGGESTED SPECIFICATIONS

### Self-threading Anchors —

#### SPECIFIED FOR ANCHORAGE INTO CONCRETE

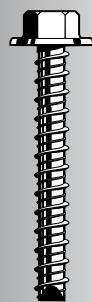

LDT Self-threading Anchor

The LDT anchor is a high performance anchor that cuts its own threads into concrete.

Anchor bodies are made of hardened carbon steel and zinc plated, **Grade 5**.

The anchors shall have a finished hex washer head with anti-rotation serrations to prevent anchor back-out. The head of the anchor is stamped with a length identification code for easy inspection.

The hole shall be drilled with carbide tipped hammer drill bits made in accordance to ANSI B212.15-1994.

## ADVANTAGES

### SAVE TIME

#### EASILY INSTALLED

- Installs in less than half the time of wedge anchors or adhesive anchors
- Simply drill a pilot hole and drive the LDT anchor by hand or impact

#### EASILY REMOVED

- No torching or grinding required to remove anchors

### SAVE MONEY

#### LOWER DRILL BIT COSTS

- Use standard ANSI bits instead of proprietary bits
- Single piece design, no nut and washer to assemble

#### USE STANDARD ANSI BITS

- No special proprietary bits to purchase or lose
- Reduce chances for anchor failure due to incorrect bit usage

## Sawtooth Threads™ diameters available on 5/8" and 3/4"

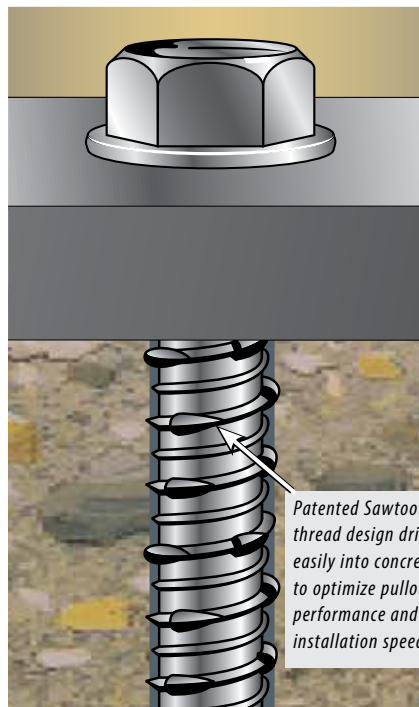

### IMPROVED PERFORMANCE IN LARGE DIAMETER HOLES

- Superior performance to wedge anchor
- Higher loads in shallow embedments
- Closer edge/spacing distance than mechanical anchors
- More threads for better thread engagement and higher pullout resistance
- Durable induction-hardened tip

### EASY INSTALLATION

- Easy 2-step installation, simply drill a pilot hole and drive
- Installs in less than half the time of a wedge anchor
- Efficient thread cutting
- Use standard drill bit sizes
- Single piece design—no nut and washer assembly
- Easily removed



## APPLICATIONS



Racking, shelving and conveyors are just a few high volume applications ideal for Large Diameter Tapcon (LDT™). The ease and speed of installation of the LDT can reduce installation time to less than half the time of typical systems used today.



For installation speed, high performance and easy removability, LDT is the anchor of choice.

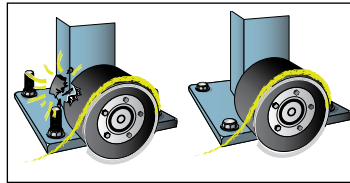

The LDT's finished head and lack of exposed threads virtually eliminates tire damage on fork lift trucks.

## FEATURES

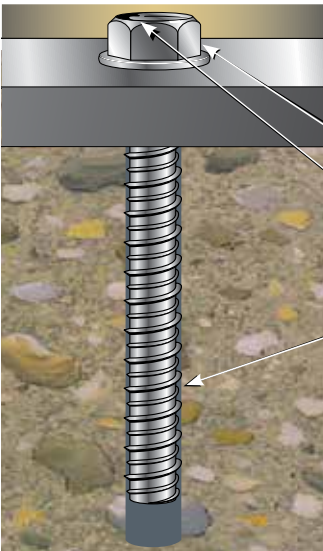

### Easy Installation

Installs into concrete by hand or impact wrench

### Anti-rotation Serrated Washer

— Prevents anchor back-out

### Extra Large Hex Washer Head

— With increased bearing surface

### Length Identification Head Stamp

— For embedment inspection after installation

### Hi-Lo Threads

— Cuts its own threads into concrete for greater pull-out resistance

### LDT 3/8" and 1/2" are available with *EnvireX* coating

1,000 hours salt spray ASTM B117. Approved for use in ACQ and MCQ lumber\*

\*Excessive content of copper in the ACQ and MCQ lumber may affect the anchor finish.

## Selection Chart

LDT Size	ANSI Standard Drill Bit Diameter	Anchor Head (Socket Size) Diameter	Washer Diameter	Minimum Embedment	Hole Depth	USE IN		
						Concrete	CMU	
							Hollow	Grout-filled
LDT 3/8"	5/16"	9/16"	13/16"	1-1/2"	2-1/2"	YES	YES	YES
LDT 1/2"	7/16"	3/4"	1"	2-1/2"	3-1/2"	YES	NO	YES
LDT 5/8"	1/2"	13/16"	1-3/16"	2-3/4"	3-3/4"	YES	NO	YES
LDT 3/4"	5/8"	15/16"	1-5/16"	3-1/4"	4-1/4"	YES	NO	YES

See page 75 for effective lengths and length indication code.

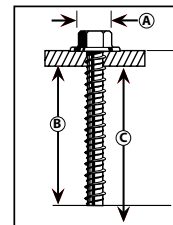

## INSTALLATION STEPS

### Installation Steps for Concrete, Lightweight Concrete and Metal Deck

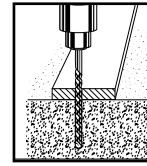

1. Using the proper size carbide bit (see chart) drill "a pilot hole at least 1" deeper than anchor embedment."

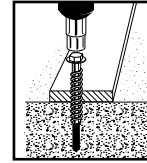

2. Using an **electric impact wrench**, or socket wrench (hand install) insert anchor into hole and tighten anchor until fully seated. (see chart for socket size) (do not over tighten).

### Installation Steps for Hollow or Grout-Filled CMU

(3/8" and 1/2" diameter)

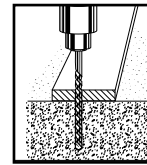

1. Using a 5/16" (for 3/8" LDT) or 7/16" (for 1/2" LDT) carbide tipped bit, drill a pilot hole at least 1" deeper than anchor embedment."

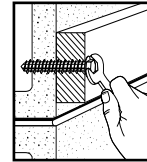

2. Using a socket wrench insert anchor into hole and hand tighten anchor until fully seated. (9/16" socket for 3/8" and 3/4" socket for 1/2") (do not over tighten).



### LDT's can be installed by hand or with an impact wrench

Installation by hand—is easy, simply using a socket wrench



Installation by impact wrench—is recommended for faster installations or for high volume projects. Installation with impact wrench—is **not** recommended for hollow block.



## SELECTION CHART

### LDT Carbon and Stainless Steel

**Carbon Steel with Zinc Plating: Meets ASTM B695 and B633 specifications for zinc plating of Sum = .0002" thickness. This coating is well suited for non-corrosive interior environments.**

**Carbon Steel with EnvireX Coating: Provides additional corrosion protection for outdoor applications.**

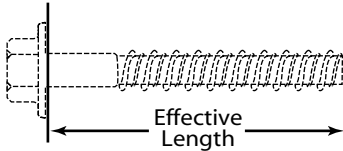

PART NUMBER CARBON STEEL ZINC PLATED	PART NUMBER CARBON STEEL EnvireX COATING	PART NUMBER FOR 410 STAINLESS STEEL	ANCHOR DIA. In. (mm)	DRILL BIT DIA. In. (mm)	EFFECTIVE LENGTH In. (mm) (see detail on left)	MAX. THICKNESS OF MATERIAL TO BE FASTENED In. (mm)	QTY/WT PER BOX lbs.	QTY/WT PER MASTER CARTON lbs.
LDT-3816	---	SLDT-3816	3/8 (9.5)	5/16 (7.9)	1-3/4 (44.5)	1/4 (6.4)	50/ 3.0	400/ 24.0
LDT-3824	---	SLDT-3824	3/8 (9.5)	5/16 (7.9)	2-1/2 (63.5)	1 (25.4)	50/ 4.5	400/ 34.0
LDT-3830	LDT-3830 X	SLDT-3830	3/8 (9.5)	5/16 (7.9)	3 (76.2)	1-1/2 (38.1)	50/ 5.0	400/ 40.0
LDT-3840	---	SLDT-3840	3/8 (9.5)	5/16 (7.9)	4 (101.6)	2-1/2 (63.5)	50/ 6.5	400/ 52.0
LDT-3850	---	SLDT-3850	3/8 (9.5)	5/16 (7.9)	5 (127.0)	3-1/2 (89.0)	40/ 7.5	320/ 60.0
LDT-1230	---	SLDT-1230	1/2 (12.7)	7/16 (11.1)	3 (76.2)	1/2 (12.7)	25/ 4.5	150/ 27.0
LDT-1240	LDT-1240 X	SLDT-1240	1/2 (12.7)	7/16 (11.1)	4 (101.6)	1-1/2 (38.1)	25/ 6.0	150/ 36.6
LDT-1250	LDT-1250 X	SLDT-1250	1/2 (12.7)	7/16 (11.1)	5 (127.0)	2-1/2 (63.5)	25/ 7.6	150/ 45.6
LDT-1260	---	---	1/2 (12.7)	7/16 (11.1)	6 (152.4)	4 (101.6)	20/ 9.0	120/ 54.0
LDT-5830	---	---	5/8 (15.9)	1/2 (12.7)	3 (76.2)	1/4 (6.4)	10/ 3.5	100/ 35.0
LDT-5840	---	---	5/8 (15.9)	1/2 (12.7)	4 (101.6)	1-1/4 (31.8)	10/ 4.0	100/ 40.0
LDT-5850	---	---	5/8 (15.9)	1/2 (12.7)	5 (127.0)	2-1/4 (57.1)	10/ 4.7	100/ 47.0
LDT-5860	---	---	5/8 (15.9)	1/2 (12.7)	6 (152.4)	3-1/4 (82.6)	10/ 5.4	50/ 27.0
LDT-3444	---	---	3/4 (19.1)	5/8 (15.9)	4-1/2 (114.3)	1-1/4 (31.8)	10/ 7.4	50/ 37.0
LDT-3454	---	---	3/4 (19.1)	5/8 (15.9)	5-1/2 (139.7)	2-1/4 (57.1)	10/ 8.1	50/ 40.5
LDT-3462	---	---	3/4 (19.1)	5/8 (15.9)	6-1/4 (158.8)	3 (76.2)	10/ 9.1	30/ 27.3

\* The stainless steel LDT's will be gold in color in order to differentiate them from the carbon steel anchors.

## DESIGN GUIDE

**For proper selection of anchor diameters based upon predrilled holes in base plates and fixtures.**

HOLE DIAMETER IN FIXTURE In. (mm)	SUGGESTED LDT DIAMETER In. (mm)
7/16 (11.1)	3/8 (9.5)
1/2 (12.7)	3/8 (9.5)
9/16 (14.3)	1/2 (12.7)
5/8 (15.9)	1/2 (12.7)
3/4 (19.1)	5/8 (15.9)
7/8 (22.2)	3/4 (19.1)

## LENGTH INDICATION CODE\*

CODE	LENGTH OF ANCHOR In. (mm)
A	1-1/2 < 2 (38.1 < 50.8)
B	2 < 2-1/2 (50.8 < 63.5)
C	2-1/2 < 3 (63.5 < 76.2)
D	3 < 3-1/2 (76.2 < 88.9)
E	3-1/2 < 4 (88.9 < 101.6)
F	4 < 4-1/2 (101.6 < 114.3)
G	4-1/2 < 5 (114.3 < 127.0)
H	5 < 5-1/2 (127.0 < 139.7)
I	5-1/2 < 6 (139.7 < 152.4)
J	6 < 6-1/2 (152.4 < 165.1)

\* Located on top of anchor for easy inspection.

## PERFORMANCE TABLE

### LDT Anchors Ultimate Tension and Shear Values (Lbs/kN) in Concrete

ANCHOR DIA. In. (mm)	EMBEDMENT DEPTH In. (mm)	f'c = 2000 PSI (13.8 MPa)		f'c = 3000 PSI (20.7 MPa)		f'c = 4000 PSI (27.6 MPa)	
		TENSION Lbs. (kN)	SHEAR Lbs. (kN)	TENSION Lbs. (kN)	SHEAR Lbs. (kN)	TENSION Lbs. (kN)	SHEAR Lbs. (kN)
3/8 (9.5)	1-1/2 (38.1)	1,336 (5.9)	2,108 (9.4)	1,652 (7.3)	2,764 (12.3)	1,968 (8.8)	3,416 (15.2)
	2 (50.8)	1,492 (6.6)	3,036 (13.5)	2,024 (9.0)	3,228 (14.4)	2,552 (11.4)	3,420 (15.2)
	2-1/2 (63.5)	3,732 (16.6)	3,312 (14.7)	3,748 (16.7)	3,364 (15.0)	3,760 (16.7)	3,424 (15.2)
	3-1/2 (88.9)	5,396 (24.0)	3,312 (14.7)	6,624 (29.5)	3,368 (15.0)	7,852 (34.9)	3,428 (15.2)
1/2 (12.7)	2 (50.8)	3,580 (15.9)	5,644 (25.1)	3,908 (17.4)	6,512 (29.0)	4,236 (18.8)	7,380 (32.8)
	3-1/2 (88.9)	7,252 (32.3)	6,436 (28.6)	8,044 (35.8)	7,288 (32.4)	8,836 (39.3)	8,140 (36.2)
	4-1/2 (114.3)	10,176 (45.3)	7,384 (32.8)	10,332 (46.0)	7,968 (35.4)	10,488 (46.7)	8,552 (38.0)
5/8 (15.9)	2-3/4 (69.9)	5,276 (23.5)	8,656 (38.5)	6,560 (29.2)	11,064 (49.2)	7,844 (34.8)	13,476 (59.9)
	3-1/2 (88.9)	7,972 (35.5)	10,224 (45.5)	9,848 (43.8)	12,144 (54.0)	11,724 (52.2)	14,060 (62.5)
	4-1/2 (114.3)	11,568 (51.5)	12,316 (54.8)	13,432 (59.8)	13,580 (60.4)	16,892 (75.1)	14,840 (66.0)
3/4 (19.1)	3-1/4 (82.6)	6,876 (30.6)	7,140 (31.8)	9,756 (43.4)	10,728 (47.7)	12,636 (56.2)	14,316 (63.6)
	4-1/2 (114.3)	10,304 (45.8)	13,120 (58.4)	14,424 (64.2)	16,868 (75.0)	18,540 (82.5)	20,612 (91.7)
	5-1/2 (139.7)	13,048 (58.0)	17,908 (79.7)	18,156 (80.8)	21,718 (96.9)	23,268 (103.5)	25,652 (114.1)

**PERFORMANCE TABLE**

**LDT Anchors**

**Allowable Tension and Shear Values\* (Lbs/kN) in Concrete Carbon and Stainless Steel**

ANCHOR DIA. In. (mm)	EMBEDMENT DEPTH In. (mm)	f'c = 2000 PSI (13.8 MPa)		f'c = 3000 PSI (20.7 MPa)		f'c = 4000 PSI (27.6 MPa)	
		TENSION Lbs. (kN)	SHEAR Lbs. (kN)	TENSION Lbs. (kN)	SHEAR Lbs. (kN)	TENSION Lbs. (kN)	SHEAR Lbs. (kN)
3/8 (9.5)	1-1/2 (38.1)	334 (1.5)	527 (2.3)	413 (1.8)	691 (3.1)	492 (2.1)	854 (3.8)
	2 (50.8)	373 (1.7)	759 (3.4)	506 (2.2)	807 (3.6)	638 (2.8)	855 (3.8)
	2-1/2 (63.5)	933 (4.2)	828 (3.7)	937 (4.2)	841 (3.7)	940 (4.2)	856 (3.8)
	3-1/2 (88.9)	1,349 (6.0)	828 (3.7)	1,656 (7.4)	842 (3.7)	1,963 (8.7)	857 (3.8)
1/2 (12.7)	2 (50.8)	895 (4.0)	1,411 (6.3)	977 (4.3)	1,628 (7.2)	1,059 (4.7)	1,845 (8.2)
	3-1/2 (88.9)	1,813 (8.0)	1,609 (7.2)	2,011 (8.9)	1,822 (8.1)	2,209 (9.8)	2,035 (9.0)
	4-1/2 (114.3)	2,544 (11.3)	1,846 (8.2)	2,583 (11.5)	1,992 (8.9)	2,622 (11.7)	2,138 (9.5)
5/8 (15.9)	2-3/4 (69.9)	1,319 (5.9)	2,164 (9.7)	1,640 (7.3)	2,766 (12.3)	1,961 (8.7)	3,369 (15.0)
	3-1/2 (88.9)	1,993 (8.9)	2,556 (11.4)	2,462 (10.9)	3,036 (13.5)	2,931 (13.0)	3,515 (15.6)
	4-1/2 (114.3)	2,892 (12.9)	3,079 (13.7)	3,358 (14.9)	3,395 (15.1)	4,223 (18.8)	3,710 (16.5)
3/4 (19.1)	3-1/4 (82.6)	1,719 (7.6)	1,785 (7.9)	2,439 (10.8)	2,682 (11.9)	3,159 (14.0)	3,579 (15.9)
	4-1/2 (114.3)	2,576 (11.5)	3,280 (14.6)	3,606 (16.0)	4,217 (18.7)	4,635 (20.6)	5,153 (22.9)
	5-1/2 (139.7)	3,262 (14.5)	4,477 (19.9)	4,539 (20.2)	5,445 (24.2)	5,817 (25.9)	6,413 (28.5)

\* Allowable values are based upon a 4 to 1 safety factor. (Ultimate/4)

**PERFORMANCE TABLE**

**LDT Anchors**

**Recommended Edge & Spacing Requirements for Tension Loads\* Carbon and Stainless Steel**

ANCHOR DIA. In. (mm)	EMBEDMENT DEPTH In. (mm)	EDGE DISTANCE REQUIRED TO OBTAIN MAX. WORKING LOAD In. (mm)	AT MIN. EDGE DISTANCE 1-3/4 Inches (44mm)	SPACING DISTANCE REQUIRED TO OBTAIN MAX. WORKING LOAD In. (mm)	LOAD FACTOR APPLIED AT MIN. SPACING DISTANCE 3 Inches (76mm)
3/8 (9.5)	1-1/2 (38.1)	2 (50.8)	70%	6 (152.4)	44%
	2 (50.8)	2 (50.8)	70%	6 (152.4)	44%
	2-1/2 (63.5)	3 (76.2)	70%	6 (152.4)	44%
	3-1/2 (88.9)	4 (101.6)	70%	6 (152.4)	44%
1/2 (12.7)	2 (50.8)	2-1/4 (57.2)	65%	8 (203.2)	27%
	3-1/2 (88.9)	3 (76.2)	65%	8 (203.2)	27%
	4-1/2 (114.3)	4 (101.6)	65%	8 (203.2)	27%
ANCHOR DIA. In. (mm)	EMBEDMENT DEPTH In. (mm)	EDGE DISTANCE REQUIRED TO OBTAIN MAX. WORKING LOAD In. (mm)	AT MIN. EDGE DISTANCE 1-3/4 Inches (44mm)	SPACING DISTANCE REQUIRED TO OBTAIN MAX. WORKING LOAD In. (mm)	LOAD FACTOR APPLIED AT MIN. SPACING DISTANCE 3.75 Inches (95.2mm)
5/8 (15.9)	2-3/4 (69.9)	6-1/4 (158.8)	65%	10 (254)	50%
	3-1/2 (88.9)	6-1/4 (158.8)	65%	10 (254)	50%
	4-1/2 (114.3)	6-1/4 (158.8)	65%	10 (254)	50%
ANCHOR DIA. In. (mm)	EMBEDMENT DEPTH In. (mm)	EDGE DISTANCE REQUIRED TO OBTAIN MAX. WORKING LOAD In. (mm)	AT MIN. EDGE DISTANCE 1-3/4 Inches (44mm)	SPACING DISTANCE REQUIRED TO OBTAIN MAX. WORKING LOAD In. (mm)	LOAD FACTOR APPLIED AT MIN. SPACING DISTANCE 4.5 Inches (114.3mm)
3/4 (19.1)	3-1/2 (82.6)	7-1/2 (191)	65%	12 (305)	50%
	4-1/2 (114.3)	7-1/2 (191)	65%	12 (305)	50%
	5-1/2 (139.7)	7-1/2 (191)	65%	12 (305)	50%

\* Edge and spacing distance shall be divided by .75 when anchors are placed in structural lightweight concrete. Linear interpolation may be used for intermediate spacing and edge distances.

For 5/8" and 3/4" LDT Anchors, the critical edge distance for these anchors is 10 times the anchor diameter. The edge distance of these anchors may be reduced to 1-3/4" provided a 0.65 load factor is used for tension loads, a 0.15 load factor is used for shear loads applied perpendicular to the edge, or a 0.60 load factor is used for shear loads applied parallel to the edge. Linear interpolation may be used for intermediate edge distances.

## PERFORMANCE TABLE

### LDT Anchors

### Recommended Edge & Spacing Requirements for Shear Loads\* Carbon and Stainless Steel

ANCHOR DIA. In. (mm)	EMBEDMENT DEPTH In. (mm)	EDGE DISTANCE REQUIRED TO OBTAIN MAX. WORKING LOAD In. (mm)	AT MIN. EDGE DISTANCE 1-3/4 Inches (44mm)	SPACING DISTANCE REQUIRED TO OBTAIN MAX. WORKING LOAD In. (mm)	LOAD FACTOR APPLIED AT MIN. SPACING DISTANCE 3 Inches (76mm)
<b>3/8 (9.5)</b>	1-1/2 (38.1)	3 (76.2)	25%	6 (152.4)	57%
	2 (50.8)	4 (101.6)	25%	6 (152.4)	57%
	2-1/2 (63.5)	5 (127.0)	25%	6 (152.4)	57%
	3-1/2 (88.9)	5 (127.0)	25%	6 (152.4)	57%
<b>1/2 (12.7)</b>	2 (50.8)	5 (127.0)	25%	8 (203.2)	60%
	3-1/2 (88.9)	5 (127.0)	25%	8 (203.2)	60%
	4-1/2 (114.3)	5-1/2 (139.7)	25%	8 (203.2)	60%
<b>5/8 (15.9)</b>	2-3/4 (69.9)	6-1/4 (158.8)	15%**/60%***	10 (254)	75%
	3-1/2 (88.9)	6-1/4 (158.8)	15%**/60%***	10 (254)	75%
	4-1/2 (114.3)	6-1/4 (158.8)	15%**/60%***	10 (254)	75%
<b>3/4 (19.1)</b>	3-1/2 (82.6)	7-1/2 (191)	15%**/60%***	12 (305)	75%
	4-1/2 (114.3)	7-1/2 (191)	15%**/60%***	12 (305)	75%
	5-1/2 (139.7)	7-1/2 (191)	15%**/60%***	12 (305)	75%

\* Edge and spacing distances shall be divided by .75 when anchors are placed in structural lightweight concrete. Linear interpolation may be used for intermediate spacing and edge distances.

\*\* 15% = shear load applied perpendicular to the edge

\*\*\* 60% = shear load applied parallel to the edge

## PERFORMANCE TABLES

### LDT Anchors

### Ultimate Tension Load (Lbs/kN) in Concrete Block (anchors should be installed by hand in hollow block)

ANCHOR DIA. In. (mm)	EMBEDMENT DEPTH In. (mm)	HOLLOW CONCRETE BLOCK		GROUT FILLED CONCRETE BLOCK	
		TENSION Lbs. (kN)	SHEAR Lbs. (kN)	TENSION Lbs. (kN)	SHEAR Lbs. (kN)
3/8 (9.5)	1-1/2 (38.1)	916 (4.1)	3,176 (14.1)	1,592 (7.1)	3,900 (17.3)
1/2 (12.7)	2-1/2 (63.5)	N/A	N/A	5,924 (26.4)	6,680 (29.7)

# LDT Anchors

## Allowable Tension and Shear\* (Lbs/kN) in Concrete Block (anchors should be installed by hand in hollow block)

ANCHOR DIA. In. (mm)	EMBEDMENT DEPTH In. (mm)	HOLLOW CONCRETE BLOCK		GROUT FILLED CONCRETE BLOCK	
		TENSION Lbs. (kN)	SHEAR Lbs. (kN)	TENSION Lbs. (kN)	SHEAR Lbs. (kN)
3/8 (9.5)	1-1/2 (38.1)	229 (1.0)	794 (3.5)	398 (1.8)	975 (4.3)
1/2 (12.7)	2-1/2 (63.5)	N/A	N/A	1,481 (6.6)	1,670 (7.4)

\* Allowable values are based upon a 4 to 1 safety factor. (Ultimate/4)

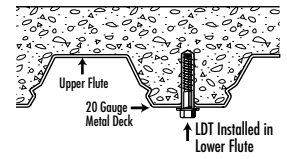

# LDT Anchors

## Anchoring Overhead in 3000 PSI Lightweight Concrete On Metal Deck

ANCHOR	DRILL HOLE DIAMETER In. (mm)	EMBEDMENT In. (mm)	3000PSI (20.7 MPa) CONCRETE			
			ULTIMATE TENSION LOAD Lbs. (kN)		ALLOWABLE WORKING LOAD Lbs. (kN)	
3/8" LDT	5/16 (7.9)	1-1/2 (38.1)	Upper Flute	2,889 (12.9)	722 (3.2)	
			Lower Flute	1,862 (8.3)	465 (2.1)	

**For use in concrete and concrete block**

**1/2" LDT**

INSTALLS IN 1/2 THE TIME

EASILY REMOVED

FINISHED HEAD

**1/2" adhesive**

DIFFICULT TO REMOVE

EXPOSED THREADS

5-STEP INSTALLATION

CURE TIME

**5/8" wedge**

PERMANENT APPLICATION

EXPOSED THREADS

DIFFICULT TO REMOVE

**DRILL BIT SIZE REQUIRED**

LDT anchors specify a smaller & less expensive drill bit than those required with the 1/2" adhesive threaded rod or the 5/8" wedge.

**HOLE DEPTH REQUIRED**

At 4-1/2" embedment the LDT anchor will give you performance (2000 PSI concrete) similar to 1/2" adhesive anchor of the same depth or 5/8" wedge anchors at 7" deep. (2000 PSI concrete)

# Tapcon +

# Tapcon +



## The Original Concrete Screw Anchor

### Approved for Cracked, Uncracked, and Seismic Conditions

Tapcon+ outperforms traditional wedge anchor products, providing greater load capacity while reducing installation time by up to 50%, offering significant cost-in-place savings on the job site.

Since patenting the original screw anchor for concrete in 1976, Tapcon® products have continued to offer innovative solutions in concrete anchoring. Now, Tapcon+ is available with International Building Code (IBC) compliance and other third party listings for use in cracked concrete and seismic applications.

#### In the Engineering Office

- Outperforms wedge anchors in tension, shear, and anchor spacing
- Approved for concrete in cracked, uncracked, and seismic conditions
- Simplicity of installation improves “build-ability” on the job site
- Blue Climaseal® for superior corrosion resistance

#### On the Job

- Installs faster and easier than wedge anchors – reducing total installed cost and delivering projects faster
- Removable for temporary fixing
- Installs without hammering and precision torque wrench
- One fastening solution for multiple applications and materials
- Does not require onsite inspection

#### Available Sizes – Tapcon+ and Accessories

Anchor Diameter	Length (Under Head)	Drill Diameter	Base Plate Hole Dia.	Quantity (Ctn/Box)	Part No.
1/4"	2-1/4"	1/4"* Tapcon+ or ANSI Bit	3/8"	800 / 100	3511407
	3"			800 / 100	3507407
3/8"	3"	3/8" ANSI	1/2"	400 / 50	3508407
	4"			400 / 50	3509407
1/2"	6"	1/2" ANSI	5/8"	160 / 20	3510407

\*Note - 1/4" diameter anchors require tight tolerance drill bit to ensure Category 1 performance.  
Use 1/4-7" Tapcon+ SDS drill bit, Part No. 3512909

#### Applications



City of Los Angeles (1/4" & 3/8" diameters) and Florida Building Code Compliant

## Product Characteristic

Nominal Diameter	1/4"		3/8"		1/2"
Head Style	Hex Head		Hex Head		Hex Head
Baseplate Hole Diameter	3/8"		1/2"		5/8"
Length (in)	2-1/4	3	3	4	6
Part No.	3511407	3507407	3508407	3509407	3510407
Coating	Blue Climaseal*		Blue Climaseal*		Blue Climaseal*
Point	Bull Nose		Bull Nose		Bull Nose
ICC-ES Report No	ESR-3699		ESR-3699		ESR-3699
Cracked Concrete	Approved		Approved		Approved
Seismic	Approved		Approved		Approved
City of Los Angeles (COLA)	Approved - COLA 25975		Approved - COLA 25975		N/A
Florida Building Code (FBC)	Approved - FL 17072		Approved - FL 17072		Approved - FL 17072

See Appendix D for Tapcon+ Strength Design Performance Values

### Performance vs. Wedge Anchor 1/4"

- Cracked concrete and seismic performance at 1/4" diameter
- Performance equals wedge anchor performance in uncracked concrete applications

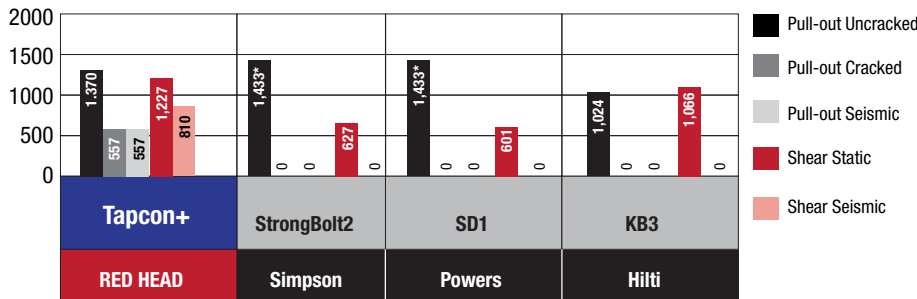

Notes: \* Concrete capacity controls failure 2,500 PSI Concrete

### Performance vs. Competitive Screw Anchor 3/8"

- Superior pull out compared to Simpson TitenHD™ and Powers Wedgebolt+™ (uncracked, cracked, and seismic)

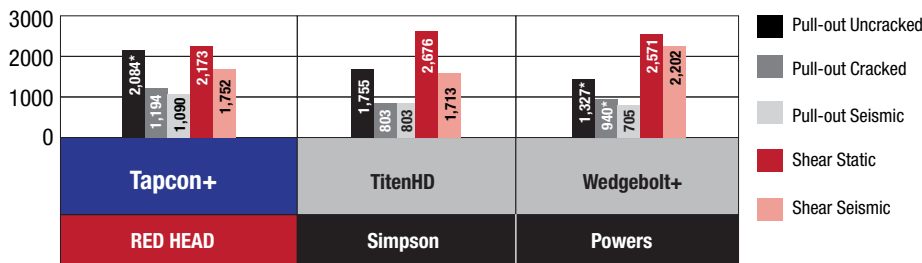

Notes: \* Concrete capacity controls failure 2,500 PSI Concrete

Advanced Threadform Technology™ for easier, faster installation

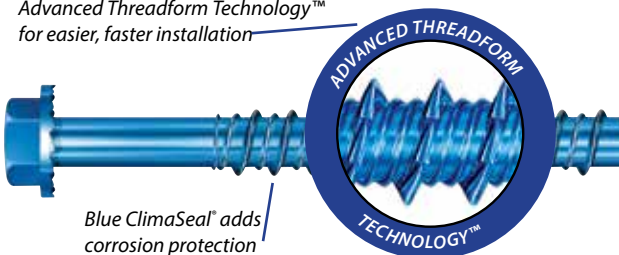

Induction hardened tip cuts into harder concrete, increases pullout.

Blue Climaseal® adds corrosion protection

Consult ICC-ESR 3699 for a full technical report. Available at [www.itwredhead.com](http://www.itwredhead.com)

## Installation Instructions



Step 1

Drill a hole that is at least a 1/4" deeper than the anchor embedment.

### Using

Variable Speed Concrete Hammer Drill & Carbide Drill Bit

1/4 x 7" Tapcon SDS Drill Bit (3512909) or  
1/4" ANSI Drill Bit or  
3/8" ANSI Drill Bit or  
1/2" ANSI Drill Bit



Step 2

Using pressurized air or a vacuum, remove the drilling debris from the hole.

### Using

Air Compressor or  
Standard Vacuum Cleaner

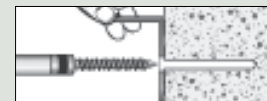

Step 3

Drive Tapcon+ screw anchor through fixture (bracket, or attachment plate), until fully seated.

### Using

Six Point Impact Socket  
3/8" Socket for 1/4" Anchors  
9/16" Socket for 3/8" Anchors  
3/4" Socket for 1/2" Anchors

### Impact Wrench

115 Max ft-lbf for 1/4" Anchors  
200 Max ft-lbf for 3/8" Anchors  
345 Max ft-lbf for 1/2" Anchors





# Boa™ Coil Expansion Anchors



## DESCRIPTION/SUGGESTED SPECIFICATIONS

### SPECIFIED FOR ANCHORAGE INTO CONCRETE

The Boa™ Coil is a high performance expansion anchor providing through fixture fastening and easy removal to keep the job moving. It's reusable with the coil replacement anchors making this anchor a low cost solution. Ideal combination of value, performance and reusability make the Boa Coil the choice for Forming and tilt-wall contractors.

**ADVANTAGES:** Easy installation, removable, reusable, high shear strength, **Grade 5 bolt.**

**APPLICATIONS:** Concrete formwork, load bearing angles, beams and columns, machinery holddown, Jersey barrier, glare screens, light rail/commuter work.

## INSTALLATION STEPS

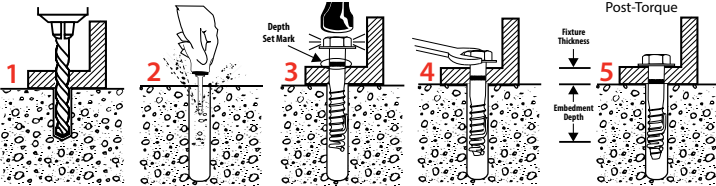

**NOTE:** To achieve maximum loads the installation process needs to be carried out as follows:

- Using the fixture as a template, drill the correct diameter and depth hole.
- Remove debris with vacuum or hand pump.
- Insert the assembled Boa Coil anchor. (The coil anchor tab points up the anchor.) Tap anchor down to depth set mark and stop.
- Tighten until washer is firmly held to the fixture and stop. Number of turns to set anchor: 1/2" 3-4 turns, 5/8" and 3/4" 4-5 turns. Ensure washer is tight and snug fit.
- The anchor is ready to take load. (The bolt can be removed leaving the coil in the hole.)

The Boa coil anchor can be reused up to 3 times in new holes.

## SELECTION CHART

### Boa Coil Anchors

PART NO.	ANCHOR DIA In. (mm)	SOCKET SIZE In.	DRILL BIT DIA. In. (mm)	HOLE DEPTH In. (mm)	FIXTURE THICKNESS AT MINIMUM EMBEDMENT TO BE FASTENED In. (mm)	QTY/WT PER BOX Lbs.	QTY/WT PER MASTER CTN Lbs.
RHCA-1230	1/2 (12.7)	3/4	1/2 (12.7)	3-1/2 (88.9)	3/8 (9.5)	25 / 4.5	150 / 27.2
RHCA-1240	1/2 (12.7)	3/4	1/2 (12.7)	4-1/2 (114.3)	1-3/8 (35.0)	25 / 5.9	150 / 35.6
RHCA-1254	1/2 (12.7)	3/4	1/2 (12.7)	6 (152.4)	2-7/8 (73.0)	25 / 7.8	150 / 46.9
RHCA-5834	5/8 (15.9)	15/16	5/8 (15.9)	4 (101.6)	3/8 (9.5)	20 / 8.8	120 / 52.5
RHCA-5850	5/8 (15.9)	15/16	5/8 (15.9)	5-1/2 (139.7)	1-7/8 (47.6)	15 / 8.5	90 / 51.0
RHCA-3444	3/4 (19.1)	1-1/8	3/4 (19.1)	5 (127.00)	1/4 (6.4)	10 / 6.4	60 / 38.3
RHCA-3460	3/4 (19.1)	1-1/8	3/4 (19.1)	6-1/2 (165.1)	1-3/4 (44.5)	10 / 8.2	60 / 49.1



Replacement coil available for easy re-use with Red Head Boa Coil Anchors only.

COIL REPLACEMENT PART NO.	QTY/WT PER BOX Lbs.	QTY/WT PER MASTER CTN Lbs.
RHC-12 (1/2")	100 / 2.8	600/16.9
RHC-58 (5/8")	100 / 2.2	600/13.1
RHC-34 (3/4")	100 / 1.3	600/7.5

## PERFORMANCE TABLES

### Boa Coil Anchors Ultimate concrete/steel capacity in concrete<sup>1</sup>

ANCHOR DIAMETER In. (mm)	HOLE DIA. In. (mm)	EFFECTIVE EMBEDMENT DEPTH In. (mm)	FIXTURE HOLE DIA. In. (mm)	TURNS TO SET ANCHOR	ULTIMATE CONCRETE CAPACITY (2) (3)						ULTIMATE STEEL STRENGTH (4)	
					2,000 PSI (13.8 MPa)		4,000 PSI (27.6 MPa)		6,000 PSI (41.4 MPa)		LBS. (kN)	
					TENSION (5) Lbs. (kN)	SHEAR Lbs. (kN)	TENSION (5) Lbs. (kN)	SHEAR Lbs. (kN)	TENSION (5) Lbs. (kN)	SHEAR Lbs. (kN)	TENSION Lbs. (kN)	SHEAR Lbs. (kN)
1/2 (12.7)	1/2 (12.7)	2 (50.8)	9/16 (14.3)	3-4	4,039 (17.9)	6,070 (27.0)	5,715 (25.4)	8,590 (38.2)	6,994 (31.1)	10,516 (46.8)	19,384 (86.2)	14,456 (64.3)
		3 (76.2)	9/16 (14.3)	3-4	7,403 (32.9)	12,082 (53.7)	10,471 (46.6)	17,089 (76.0)	12,822 (57.0)	20,937 (93.1)		
5/8 (15.9)	5/8 (15.9)	2-3/8 (60.3)	11/16 (17.5)	4-5	5,291 (23.5)	8,800 (39.1)	7,483 (33.3)	12,445 (55.4)	9,162 (40.8)	15,242 (67.8)	30,152 (134.1)	21,937 (97.6)
		3-7/8 (98.4)	11/16 (17.5)	4-5	10,855 (48.3)	19,999 (89.0)	15,355 (68.3)	28,285 (125.8)	18,802 (83.6)	34,636 (154.0)		
3/4 (19.1)	3/4 (19.1)	3-1/4 (82.6)	13/16 (20.6)	4-5	8,479 (37.7)	16,567 (73.7)	11,991 (53.3)	23,427 (104.2)	14,682 (65.3)	28,690 (127.6)	43,360 (192.9)	32,031 (142.5)
		4-1/2 (114.3)	13/16 (20.6)	4-5	13,555 (60.3)	27,239 (121.2)	19,171 (85.3)	38,518 (171.3)	23,478 (104.4)	47,173 (209.8)		

(1) Use lower value of either concrete or steel (2) Concrete capacity based on Concrete Capacity Design method and verified by test data (3) Influence factors must be applied to concrete strength values (4) Steel strength based on .57 Fu Ag for shear and 0.75 Fu Ag for tension (5) Test results when reused four times; maximum 20% reduction in tensile capacity; no reduction in shear

### Boa Coil Anchors Allowable concrete/steel capacity in concrete<sup>1</sup>

ANCHOR DIAMETER In. (mm)	HOLE DIA. In. (mm)	EFFECTIVE EMBEDMENT DEPTH In. (mm)	FIXTURE HOLE DIA. In. (mm)	TURNS TO SET ANCHOR	RECOMMENDED WORKING LOADS IN CONCRETE (2) (3)						ALLOWABLE STEEL STRENGTH (4)	
					2,000 PSI (13.8 MPa)		4,000 PSI (27.6 MPa)		6,000 PSI (41.4 MPa)		LBS. (kN)	
					TENSION (5) Lbs. (kN)	SHEAR Lbs. (kN)	TENSION (5) Lbs. (kN)	SHEAR Lbs. (kN)	TENSION (5) Lbs. (kN)	SHEAR Lbs. (kN)	TENSION Lbs. (kN)	SHEAR Lbs. (kN)
1/2 (12.7)	1/2 (12.7)	2 (50.8)	9/16 (14.3)	3-4	1,011 (4.5)	1,517 (6.7)	1,430 (6.4)	2,147 (9.5)	1,751 (7.8)	2,629 (11.7)	8,529 (37.9)	5,579 (24.8)
		3 (76.2)	9/16 (14.3)	3-4	1,852 (8.2)	3,020 (13.4)	2,619 (11.6)	4,272 (19.0)	3,208 (14.3)	5,234 (23.3)		
5/8 (15.9)	5/8 (15.9)	2-3/8 (60.3)	11/16 (17.5)	4-5	1,324 (5.9)	2,200 (9.8)	1,872 (8.3)	3,111 (13.8)	2,293 (10.2)	3,810 (16.9)	13,266 (59.0)	8,466 (37.7)
		3-7/8 (98.4)	11/16 (17.5)	4-5	2,715 (12.1)	5,000 (22.2)	3,840 (17.1)	7,071 (31.5)	4,703 (20.9)	8,660 (38.5)		
3/4 (19.1)	3/4 (19.1)	3-1/4 (82.6)	13/16 (20.6)	4-5	2,121 (9.4)	4,141 (18.4)	2,999 (13.3)	5,556 (24.7)	3,673 (16.3)	7,172 (31.9)	19,078 (84.9)	12,362 (55.0)
		4-1/2 (114.3)	13/16 (20.6)	4-5	3,390 (15.1)	6,810 (30.3)	4,794 (21.3)	9,630 (42.8)	5,872 (26.2)	11,793 (52.4)		

(1) Use lower value of either concrete or steel (2) Safety factor 4 (3) Influence factors must be applied to concrete strength values (4) Steel strength based on .22 Fu Ag for shear and 0.33 Fu Ag for tension (5) Test results when reused four times; maximum 20% reduction in tensile capacity; no reduction in shear

**DESCRIPTION/SUGGESTED SPECIFICATIONS**

**Drop-In, Shell-Type Anchors—**

**SPECIFIED FOR ANCHORAGE INTO CONCRETE**

Drop-In, shell-type anchors feature an internally threaded, all-steel shell with expansion cone insert and flush embedment lip. Anchors are manufactured from zinc-plated carbon steel, 18-8 stainless steel and 316 stainless steel.

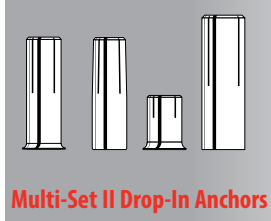

Multi-Set II Drop-In Anchors

Anchors should be installed with carbide tipped hammer drill bits made in accordance to ANSI B212.15-1994 specifications.

Anchors should be tested to ASTM E488 criteria and listed by ICC-ES. Anchors should also be listed by the following agencies as required by the local building code: UL, FM, City of Los Angeles, California State Fire Marshal and Caltrans.

**Multi-Set II<sup>®</sup>  
Drop-In Anchors**

**Internally  
Threaded Heavy-  
Duty Anchoring  
Systems**

**ADVANTAGES**

**Depth Charge Stop Drill  
and RX Drop-In Anchors**

Ideal for Hollow-Core, Pre-Cast Plank and Post Tension Slabs



- Optimized for use in hollow-core, pre-cast plank and post-tension slabs
- Lip keeps anchor flush during installation
- Shallow drilling—fast installation



RX Drop-In Anchor



See page 81 for kits

**RM Drop-In Anchor**



- Lipped anchor body keeps anchor flush
- Easy installation
- Keeps all rods same length
- Easy inspection
- Available in carbon steel, 18-8 and 316 stainless steel

**RL Drop-In Anchor**



- Below surface setting for easy patch work

**Coil Thread Anchor**



- Quick thread attachment—ideal for 1 sided forming
- Use coil rod on job
- 2 diameters (1/2" and 3/4")

## APPLICATIONS



Pumps and heavy piping are common applications for larger diameter Multi-Set Drop-In Anchors.



Cable tray and strut suspended from concrete ceilings are ideal Multi-Set applications. In post-tension or hollow-core slabs use the RX-38.



The Multi-Set Anchor is the standard for pipe-hanging. The RM version has a retainer lip to keep all anchors flush at the surface, keeping all your threaded rod the same length.

## FEATURES

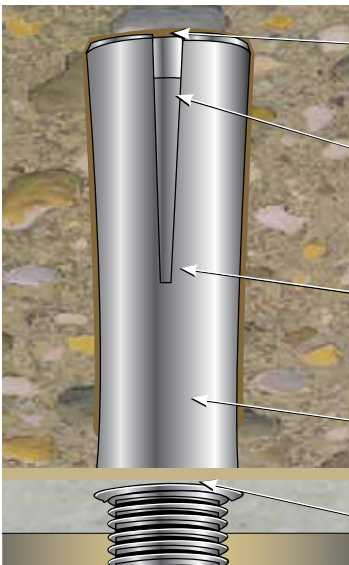

**Expander Slots**—allow for easy setting and superior performance

**Cone Insert**—that expands the anchor when driven with setting tool and hammer

**Body**—available in zinc-plated steel, 18-8 stainless steel, and 316 stainless steel

**Easy Depth Inspection**—keeps threaded rod drop lengths consistent

**Retainer Lip**—to keep anchor flush with surface

For use with threaded rods or headed bolts (supplied by contractor)

## APPROVALS/LISTINGS

Meets or exceeds U.S. Government G.S.A. Specification A-A-55614 Type 1 (Formerly GSA: FF-S-325 Group VIII)

Underwriters Laboratories

Factory Mutual

Caltrans

For the most current approvals/listings visit: [www.itw-redhead.com](http://www.itw-redhead.com)

## INSTALLATION STEPS

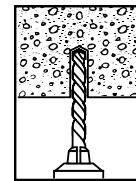

To set anchor flush with surface:

1. Drill hole to required embedment (see Table on page 69).

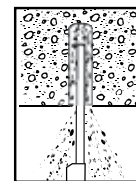

2. Clean hole with pressurized air.

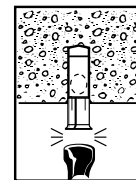

3. Drive anchor flush with surface of concrete.

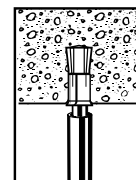

4. Expand anchor with setting tool provided (see chart on page 69). Anchor is properly expanded when shoulder of setting tool is flush with top of anchor.

## SELECTION CHART

### Multi-Set II Depth Charge Bits

PART NUMBER	DESCRIPTION FEATURE BENEFITS	DRILLING DEPTH
DCX-138	3/8" Depth Charge Stop Drill	3/4"
DCX-112	1/2" Depth Charge Stop Drill	1"



■ Shoulder prevents over drilling. Less likely to hit reinforcing steel or post-tension cable in concrete



■ No wasted time or energy drilling deeper than necessary

■ Prevents anchor from dropping too far into hole below work surface

## SELECTION CHARTS



### Multi-Set II Drop-In Anchors

**PART NUMBER RT-138**  
1 setting tool per master carton  
(See above for part numbers.)

**PART NUMBER RTX-138**  
For use with RX-38 only.

**PART NUMBER RTX-112**  
For use with RX-12 only.

USER TYPE / APPLICATION	BASE MATERIAL	CORROSION RESISTANCE LEVEL	DROP-IN ANCHOR TYPE	PART NUMBER	SETTING TOOL PART NUMBER*	BOLT SIZE-THREADS PER INCH	DRILL BIT DIA. In. (mm)	THREAD DEPTH In. (mm)	EMBEDMENT MIN. HOLE DEPTH*** In. (mm)	QTY/WT PER BOX lbs.	QTY/WT PER MASTER CTN lbs. *	
HVAC/Fire Sprinkler Plumber (Pipe-fitter)	Solid concrete/lightweight fill deck	Low	RM	RM-14	RT-114	1/4" - 20	3/8 (9.5)	3/8 (9.5)	1 (25.4)	100/ 2.6	1000/ 28	
				RM-38	RT-138	3/8" - 16	1/2 (12.7)	1/2 (12.7)	1-5/8 (41.3)	50/ 3.4	500/ 36	
				RM-12	RT-112	1/2" - 13	5/8 (15.9)	3/4 (19.1)	2 (50.8)	50/ 5.8	400/ 49	
				RM-58	RT-158	5/8" - 11	7/8 (22.2)	1 (25.4)	2-1/2 (63.5)	25/ 7.8	125/ 41	
				RM-34	RT-134	3/4" - 10	1 (25.4)	1-1/4 (31.8)	3-3/16 (81.0)	25/11.9	100/ 49	
	Hollow-core pre-cast or Post-tension	Low	RX	RX-38	RTX-138	3/8" - 16	1/2 (12.7)	3/8 (9.5)	3/4 (19.1)	100/ 3.5	1000/ 36	
				RX-12	RTX-112	1/2" - 13	5/8 (15.9)	1/2 (12.7)	1 (25.4)	50/ 3.0	500/ 31	
	Solid concrete/lightweight fill deck	Medium	SRM**	18-8 S.S.	SRM-14	RT-114	1/4" - 20	3/8 (9.5)	3/8 (9.5)	1 (25.4)	100/ 2.7	1000/ 28
					SRM-38	RT-138	3/8" - 16	1/2 (12.7)	1/2 (12.7)	1-5/8 (41.3)	50/ 3.4	500/ 36
					SRM-12	RT-112	1/2" - 13	5/8 (15.9)	3/4 (19.1)	2 (50.8)	50/ 6.0	400/ 50
SRM-58					RT-158	5/8" - 11	7/8 (22.2)	1 (25.4)	2-1/2 (63.5)	25/ 7.9	125/ 42	
SRM-34					RT-134	3/4" - 10	1 (25.4)	1-1/4 (31.8)	3-3/16 (81.0)	25/12.0	100/ 50	
concrete	High	SSRM**	SSRM-12	RT-112	1/2" - 13	5/8 (15.9)	3/4 (19.1)	2 (50.8)	50/ 6.0	400/50		
Concrete Contractor, General Contractor, Highway	Solid concrete	Low	CL-Coil Threaded	CL-12	RT-112	1/2" - 6	5/8 (15.9)	3/4 (19.1)	2 (50.8)	50/ 5.7	400/ 47	
				CL-34	RT-134	3/4" - 4.5	1 (25.4)	1-1/4 (31.8)	3-3/16 (81.0)	25/11.9	100/ 49	
Concrete Cutting/Sawing Contractor/Misc. Metal	Solid concrete/lightweight fill deck	Low	RL (w/o lip)	RL-14	RT-114	1/4" - 20	3/8 (9.5)	3/8 (9.5)	1 (25.4)	100/ 2.6	1000/ 28	
				RL-38	RT-138	3/8" - 16	1/2 (12.7)	1/2 (12.7)	1-5/8 (41.3)	50/ 3.4	500/ 36	
				RL-12	RT-112	1/2" - 13	5/8 (15.9)	3/4 (19.1)	2 (50.8)	50/ 5.8	400/ 49	
				RL-58	RT-158	5/8" - 11	7/8 (22.2)	1 (25.4)	2-1/2 (63.5)	25/ 7.8	125/ 41	
				RL-34	RT-134	3/4" - 10	1 (25.4)	1-1/4 (31.8)	3-3/16 (81.0)	25/11.9	100/ 49	

\* 1 setting tool per master carton.

\*\* For continuous extreme low temperature, use stainless steel.

\*\*\*Embedment is equal to overall length of Drop-In Anchor

### Multi-Set II RX Drop-In Kits

Part No.	Description
RX-38	3/8" drop-in using 1/2" drill bit
RTX-138	Setting Tool
DCX-138	Depth Charge Stop Drill

Part No.	Description
RX-12	1/2" drop-in using 5/8" drill bit
RTX-112	Setting Tool
DCX-112	Depth Charge Stop Drill

## PERFORMANCE TABLE

### Multi-Set II Drop-In Anchors

### Ultimate Tension and Shear Values (Lbs/kN) in Concrete\*

BOLT DIA. In. (mm)	DRILL BIT SIZE In. (mm)	MIN. EMBEDMENT DEPTH In. (mm)	ANCHOR TYPE	TENSION Lbs. (kN)			SHEAR Lbs. (kN)
				f <sub>c</sub> = 2000 PSI (13.8 MPa)	f <sub>c</sub> = 4000 PSI (27.6 MPa)	f <sub>c</sub> = 6000 PSI (41.4 MPa)	f <sub>c</sub> > 2000 PSI (13.8 MPa)
1/4 (6.4)	3/8 (9.5)	1 (25.4)	RM, RL or CL-Carbon or SRM-18-8 S.S. or SSRM-316 S.S.	1,680 (7.5)	2,360 (10.5)	2,980 (13.3)	1,080 (4.8)
3/8 (9.5)	1/2 (12.7)	1-5/8 (41.3)		2,980 (13.3)	3,800 (16.9)	6,240 (27.8)	3,160 (14.1)
1/2 (12.7)	5/8 (15.9)	2 (50.8)		3,300 (14.7)	5,840 (26.0)	8,300 (36.9)	4,580 (20.4)
5/8 (15.9)	7/8 (22.2)	2-1/2 (63.5)		5,500 (24.5)	8,640 (38.4)	11,020 (49.0)	7,440 (33.1)
3/4 (19.1)	1 (25.4)	3-3/16 (81.0)		8,280 (36.8)	9,480 (42.2)	12,260 (54.5)	10,480 (46.6)

\* Allowable values are based upon a 4 to 1 safety factor. Divide by 4 for allowable load values.

\* For continuous extreme low temperature applications, use stainless steel.

### Multi-Set II Drop-In Anchors

### Ultimate Tension and Shear Values (Lbs/kN) in Lightweight Concrete\*

BOLT DIA. In. (mm)	DRILL BIT SIZE In. (mm)	MINIMUM EMBEDMENT DEPTH In. (mm)	ANCHOR TYPE	LIGHTWEIGHT CONCRETE f <sub>c</sub> = 3000 PSI (20.7 MPa)		LOWER FLUTE OF STEEL DECK WITH LIGHTWEIGHT CONCRETE FILL f <sub>c</sub> = 3000 PSI (20.7 MPa)	
				TENSION Lbs. (kN)	SHEAR Lbs. (kN)	TENSION Lbs. (kN)	SHEAR Lbs. (kN)
3/8 (9.5)	1/2 (12.7)	1-5/8 (39.7)	RM, RL or CL-Carbon or SRM-18-8 S.S. or SSRM-316 S.S.	2,035 (9.1)	1,895 (8.4)	3,340 (14.9)	4,420 (19.6)
1/2 (12.7)	5/8 (15.9)	2 (50.8)		2,740 (12.2)	2,750 (12.2)	3,200 (14.2)	4,940 (22.0)
5/8 (15.9)	7/8 (22.2)	2-1/2 (63.5)		4,240 (18.9)	4,465 (19.9)	5,960 (26.5)	5,840 (26.0)
3/4 (19.1)	1 (25.4)	3-3/16 (81.0)		5,330 (23.7)	6,290 (28.0)	8,180 (36.4)	9,120 (40.6)

\* Allowable values are based upon a 4 to 1 safety factor. Divide by 4 for allowable load values.

### Multi-Set II Drop-In Anchors

### Recommended Edge and Spacing Distance Requirements\*

BOLT DIA. In. (mm)	DRILL BIT SIZE In. (mm)	EMBEDMENT DEPTH In. (mm)	ANCHOR TYPE	EDGE DISTANCE REQUIRED TO OBTAIN MAX. WORKING LOAD In. (mm)	MIN. EDGE DISTANCE AT WHICH LOAD FACTOR APPLIED =.80 FOR TENSION =.70 FOR SHEAR In. (mm)	SPACING REQUIRED TO OBTAIN MAX. WORKING LOAD In. (mm)	MIN. ALLOWABLE SPACING BETWEEN ANCHORS LOAD FACTOR APPLIED =.80 FOR TENSION =.55 FOR SHEAR In. (mm)
1/4 (6.4)	3/8 (9.5)	1 (25.4)	RM, RL or CL-Carbon or SRM-18-8 S.S. or SSRM-316 S.S.	1-3/4 (44.5)	7/8 (22.2)	3-1/2 (88.9)	1-3/4 (44.5)
3/8 (9.5)	1/2 (12.7)	1-5/8 (41.3)		2-7/8 (73.0)	1-7/16 (36.5)	5-11/16 (144.5)	2-7/8 (73.0)
1/2 (12.7)	5/8 (15.9)	2 (50.8)		3-1/2 (88.9)	1-3/4 (44.5)	7 (177.8)	3-1/2 (88.9)
5/8 (15.9)	7/8 (22.2)	2-1/2 (63.5)		4-3/8 (111.1)	2-3/16 (55.6)	8-3/4 (222.3)	4-3/8 (111.1)
3/4 (19.1)	1 (25.4)	3-3/16 (81.0)		5-5/8 (142.9)	2-13/16 (71.4)	11-3/16 (284.2)	5-5/8 (142.9)

\* Spacing and edge distances shall be divided by 0.75 when anchors are placed in structural lightweight concrete. Linear interpolation may be used for intermediate spacing and edge distances.

## PERFORMANCE TABLES

### Multi-Set II Drop-In Anchors Ultimate Tension and Shear Values (Lbs/kN) for RX-series (3/4" and 1" Embedment)\*

BOLT DIA. In. (mm)	DRILL BIT SIZE In. (mm)	EMBEDMENT In. (mm)	2500 PSI (17.2 MPa) CONCRETE		4000 PSI (27.6 MPa) CONCRETE		HOLLOW CORE	
			TENSION Lbs. (kN)	SHEAR Lbs. (kN)	TENSION Lbs. (kN)	SHEAR Lbs. (kN)	TENSION Lbs. (kN)	SHEAR Lbs. (kN)
3/8 (9.5)	1/2 (12.7)	3/4 (19.1)	1,571 (7.0)	2,295 (10.2)	1,987 (8.8)	2,903 (12.9)	1,908 (8.5)	2,401 (10.7)
1/2 (12.7)	5/8 (15.9)	1 (25.4)	2,113 (9.4)	2,585 (11.5)	2,673 (11.9)	3,270 (14.5)	2,462 (11.0)	2,401 (10.7)

\* The tabulated values are for RX anchors installed at a minimum of 12 diameters on center and minimum edge distance of 6 diameters for 100 percent anchor efficiency. Spacing and edge distance may be reduced to 6 diameters spacing and 3 diameter edge distance provided the values are reduced 50 percent. Linear Interpolation may be used for intermediate spacings and edge margins.

\* Allowable values are based upon a 4 to 1 safety factor. Divide by 4 for allowable load values.

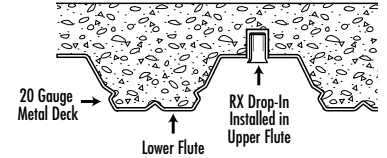

### Multi-Set II Drop-In Anchors Anchoring Overhead in 3000 PSI Lightweight Concrete On Metal Deck

ANCHOR	DRILL HOLE DIAMETER In. (mm)	EMBEDMENT In. (mm)	3000PSI (20.7 MPa) CONCRETE			
			ULTIMATE TENSION LOAD Lbs. (kN)		ALLOWABLE WORKING LOAD Lbs. (kN)	
RX-38 Drop-In	1/2 (12.7)	3/4 (19.1)	Upper Flute	1,410 (6.3)	353 (1.6)	
			Lower Flute	1,206 (5.4)	301 (1.3)	

\* Allowable values are based upon a 4 to 1 safety factor. Divide by 4 for allowable load values.

### Combined Tension and Shear Loading—for Multi-Set Anchors

Allowable loads for anchors subjected to combined shear and tension forces are determined by the following equation:

$$(P_s/P_t)^{5/3} + (V_s/V_t)^{5/3} \leq 1$$

$P_s$  = Applied tension load

$V_s$  = Applied shear load

$P_t$  = Allowable tension load

$V_t$  = Allowable shear load



# Dynabolt<sup>®</sup> Sleeve Anchors

**Versatile,  
Medium-Duty  
Sleeve Anchor**



**Dynabolt  
Hex Nut Sleeve Anchor**

## APPROVALS/LISTINGS

Meets or exceeds U.S. Government G.S.A. Specification A-A-1922A (Formerly GSA: FF-S-325 Group II, Type 3, Class 3)  
Factory Mutual

## DESCRIPTION/SUGGESTED SPECIFICATIONS

### Sleeve Type Anchors—

**SPECIFIED FOR ANCHORAGE INTO CONCRETE, GROUT-FILLED CONCRETE BLOCK, HOLLOW CONCRETE BLOCK AND BRICK**



**Dynabolt  
Masonry  
Sleeve  
Anchor**

Sleeve type anchors feature a split expansion sleeve over a threaded stud bolt body and integral expander, nut and washer.

Anchors are made of Plated Carbon Steel, or Type 18-8 Stainless Steel.

Anchors should be installed with carbide tipped hammer drill bits made in accordance to ANSI B212.15-1994.

Anchors are tested to ASTM E488 criteria.

## ADVANTAGES

- Anchor diameter equals hole diameter
- Available in hex head and three other head styles
- Available 1/4 - 3/4" diameter up to 6-1/4" length
- Zinc plated carbon steel and 304 stainless steel
- Provides full 360° hole contact over large area and reduces concrete stress
- Heavy-loading capacity
- Preassembled for faster, easier installations
- Dynabolt can be installed through object to be fastened
- Sleeve design improves holding power
- No pre-spotting of holes necessary

### Available Head Styles

Full range of head style, corrosion protection, and sizes makes the Dynabolt Sleeve the right product for almost any application.

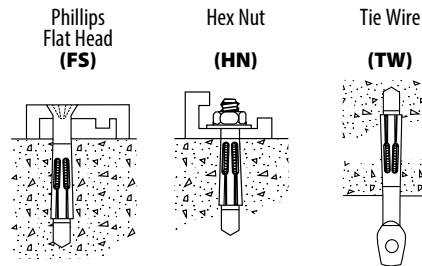

## INSTALLATION STEPS

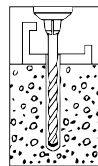

**1.** Use a carbide tipped drill bit whose diameter is equal to the anchor. See Chart to determine proper size bit for anchor used. Drill hole to any depth exceeding minimum embedment. Clean hole.

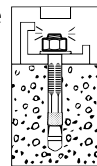

**2.** Insert assembled anchor through fixture and into hole so that washer or head is flush with materials to be fastened.

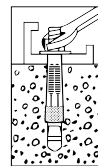

**3.** Expand anchor by tightening nut or head 2 to 3 turns.

## APPLICATIONS

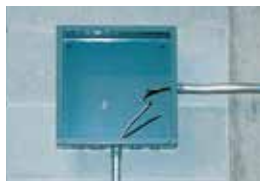

Electrical junction boxes are common applications for the Dynabolt Sleeve anchor because it works well in solid concrete, concrete block, and brick. It is also available in several finished head styles.



The Dynabolt Sleeve anchor works well in hollow materials like brick and block. It is available in zinc-plated carbon steel and 304 stainless steel.



Door and window frames are commonly attached to the structure with Dynabolt Sleeve anchors because of their finished & threshold head styles and performance in block & brick.

## SELECTION CHART

# Dynabolt

Carbon Steel with Zinc Plating



**Typical Applications**—  
Shelf ledgers, electrical boxes,  
conduit

**Environment**—Interior  
(non-corrosive)

**Level of Corrosion**—Low

### \* Effective Anchor Length

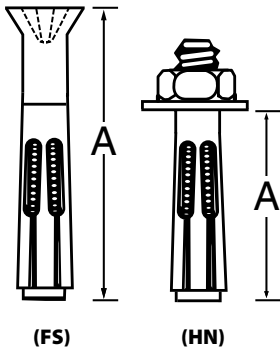

HEAD STYLE	PART NUMBER	ANCHOR DIA. & DRILL BIT SIZE	EFFECTIVE ANCHOR LENGTH* In. (mm)	BOLT DIA./ THREADS PER INCH	MIN. EMBEDMENT In. (mm)	MAX. THICKNESS OF MATERIAL TO BE FASTENED In. (mm)	QTY/WT PER BOX lbs.	QTY/WT PER MASTER CARTON lbs.
HEX NUT	HN-1614	5/16"	1-1/2 (38.1)	1/4" /20	1-1/4 (31.8)	1/4 (6.4)	100/ 4.0	1000/ 41
	HN-3817	3/8"	1-7/8 (47.6)	5/16" /18	1-1/2 (38.1)	3/8 (9.5)	50/ 3.5	500/ 36
	HN-3830		3 (76.2)	5/16" /18	1-1/2 (38.1)	1-1/2 (38.1)	50/ 4.9	400/ 40
	HN-1222	1/2"	2-1/4 (57.2)	3/8" /16	1-7/8 (47.6)	3/8 (9.5)	25/ 3.3	250/ 34
	HN-1230		3 (76.2)	3/8" /16	1-7/8 (47.6)	1-1/8 (28.6)	25/ 4.0	200/ 33
	HN-1240		4 (101.6)	3/8" /16	1-7/8 (47.6)	2-1/8 (54.0)	25/ 5.3	200/ 44
	HN-5830	5/8"	3 (76.2)	1/2" /13	2 (50.8)	1 (25.4)	25/ 7.0	150/ 46
HN-5842	4-1/4 (108.0)		1/2" /13	2 (50.8)	2-1/4 (57.2)	10/ 3.9	100/ 41	
HN-3440	3/4"	4 (101.6)	5/8" /11	2-1/4 (57.2)	1-3/4 (44.5)	5/ 3.2	50/ 33	
PHILLIPS FLAT HEAD	FS-3840	3/8" (head dia. .722)	4 (101.6)	5/16" /18	1-1/2 (38.1)	2-1/2 (63.5)	50/ 5.3	400/ 44
	FS-3850		5 (127.0)	5/16" /18	1-1/2 (38.1)	3-1/2 (88.9)	50/ 5.6	300/ 40
	FS-3860		6 (152.4)	5/16" /18	1-1/2 (38.1)	4-1/2 (114.3)	50/ 8.0	300/ 48
TW WIRE	TW-1614	5/16"	1-1/2 (38.1)	1/4" /20	1-1/2 (38.1)	9/32 (7.1)	100/ 4.9	1000/ 50

\* Phillips flat head uses a standard 80°–82° counter sink.

## SELECTION CHART

# Dynabolt

Type 304 Stainless Steel



**Typical Applications**—  
Cladding and Brick Ties

**Environment**—Slight to  
moderate degree of pollution

**Level of Corrosion**—  
Medium

HEAD STYLE	PART NUMBER	ANCHOR DIA. & DRILL BIT SIZE	EFFECTIVE ANCHOR LENGTH* In. (mm)	BOLT DIA./ THREADS PER INCH	MIN. EMBEDMENT In. (mm)	MAX. THICKNESS OF MATERIAL TO BE FASTENED In. (mm)	QTY/WT PER BOX lbs.	QTY/WT PER MASTER CARTON lbs.
HEX NUT	SHN-3817	3/8"	1-7/8 (47.6)	5/16" /18	1-1/2 (38.1)	3/8 (9.5)	50/ 3.5	500/ 36
	SHN-1222	1/2"	2-1/4 (57.2)	3/8" /16	1-7/8 (47.6)	3/8 (9.5)	25/ 3.3	250/ 34
	SHN-1240		4 (101.6)	3/8" /16	1-7/8 (47.6)	2-1/8 (54.0)	25/ 5.3	200/ 44
PHILLIPS FLAT HEAD	SFS-3826	3/8"	2-7/8 (73.0)	5/16" /18	1-1/2 (38.1)	1-3/8 (34.9)	50/ 3.8	500/ 40
	SFS-3840		4 (101.6)	5/16" /18	1-1/2 (38.1)	2-1/2 (63.5)	50/ 5.3	400/ 44

\* Flat head uses a standard 80°–82° counter sink.

For continuous extreme low temperature applications, use stainless steel.

## PERFORMANCE TABLES

### Dynabolt Sleeve Anchors

### Ultimate Tension and Shear Values in Concrete (Lbs/kN)\*

ANCHOR DIA. In. (mm)	INSTALLATION TORQUE Ft. Lbs. (Nm)	BOLT DIA. In. (mm)	MINIMUM EMBEDMENT DEPTH In. (mm)	ANCHOR TYPE (STEEL)	f <sub>c</sub> = 2000 PSI (13.8 MPa)		f <sub>c</sub> = 3000 PSI (20.7 MPa)		f <sub>c</sub> = 4000 PSI (27.6 MPa)	
					TENSION Lbs. (kN)	SHEAR Lbs. (kN)	TENSION Lbs. (kN)	SHEAR Lbs. (kN)	TENSION Lbs. (kN)	SHEAR Lbs. (kN)
1/4 (6.4)	3.5 (4.7)	3/16 (4.8)	1-1/8 (28.6)	Carbon or Stainless	1,200 (5.3)	1,215 (5.4)	1,325 (5.9)	1,215 (5.4)	1,450 (6.4)	1,215 (5.4)
5/16 (7.9)	8 (10.8)	1/4 (6.4)	1-1/4 (31.8)		1,400 (6.2)	2,040 (9.1)	1,920 (8.5)	2,220 (9.9)	2,600 (11.6)	2,400 (10.7)
3/8 (9.5)	14 (19.0)	5/16 (7.9)	1-1/2 (38.1)		1,620 (7.2)	2,560 (11.4)	2,240 (10.0)	2,800 (12.5)	3,100 (13.8)	3,040 (13.5)
1/2 (12.7)	20 (27.1)	3/8 (9.5)	1-7/8 (47.6)		2,220 (9.9)	3,250 (14.5)	3,140 (14.0)	4,000 (17.8)	4,400 (19.6)	4,500 (20.0)
5/8 (15.9)	48 (65.1)	1/2 (12.7)	2 (50.8)		3,080 (13.7)	6,440 (28.6)	4,400 (19.6)	7,240 (32.2)	6,120 (27.2)	8,080 (35.9)
3/4 (19.1)	90 (122.0)	5/8 (15.9)	2-1/4 (57.2)		4,200 (18.7)	10,200 (45.4)	6,060 (27.0)	11,600 (51.6)	8,900 (39.6)	13,100 (58.3)

\* For continuous extreme low temperature applications, use stainless steel.

For AN-1405, Ultimate Pullout: 500 lbs. & Ultimate Shear: 1751 lbs. based on 4,000 psi.

\* Allowable values are based upon a 4 to 1 safety factor. Divide by 4 for allowable load values

### Dynabolt Sleeve Anchors

### Ultimate Tension and Shear Values in Lightweight Concrete (Lbs/kN)\*

ANCHOR DIA. In. (mm)	INSTALLATION TORQUE Ft. Lbs. (Nm)	BOLT DIA. In. (mm)	MINIMUM EMBEDMENT DEPTH In. (mm)	ANCHOR TYPE (STEEL)	f <sub>c</sub> = 4000 PSI (27.6 MPa)		f <sub>c</sub> = 6000 PSI (41.4 MPa)	
					TENSION Lbs. (kN)	SHEAR Lbs. (kN)	TENSION Lbs. (kN)	SHEAR Lbs. (kN)
1/4 (6.4)	3.5 (4.7)	3/16 (4.8)	1-1/8 (28.6)	Carbon or Stainless	870 (3.9)	730 (3.2)	1,066 (4.7)	894 (4.0)
5/16 (7.9)	8 (10.8)	1/4 (6.4)	1-1/4 (31.8)		1,260 (5.6)	1,680 (7.5)	1,440 (6.4)	2,220 (9.9)
3/8 (9.5)	14 (19.0)	5/16 (7.9)	1-1/2 (38.1)		1,620 (7.2)	2,300 (10.2)	2,240 (10.0)	2,800 (12.5)
1/2 (12.7)	25 (33.9)	3/8 (9.5)	1-7/8 (47.6)		2,600 (11.6)	2,400 (10.7)	3,160 (14.1)	2,400 (10.7)
5/8 (15.9)	48 (65.1)	1/2 (12.7)	2 (50.8)		3,240 (14.4)	5,600 (24.9)	4,300 (19.1)	7,840 (34.9)
3/4 (19.1)	90 (122.0)	5/8 (15.9)	2-1/4 (57.2)		3,640 (16.2)	8,640 (38.4)	5,800 (25.8)	12,480 (55.5)

### Dynabolt Sleeve Anchors

### Ultimate Tension and Shear Values in Concrete Masonry Units (Lbs/kN)\*

ANCHOR DIA. In. (mm)	INSTALLATION TORQUE Ft. Lbs. (Nm)	BOLT DIA. In. (mm)	MINIMUM EMBEDMENT DEPTH In. (mm)	ANCHOR TYPE (STEEL)	LIGHTWEIGHT				MEDIUM WEIGHT			
					HOLLOW CORE		GROUT FILLED		HOLLOW CORE		GROUT FILLED	
					TENSION Lbs. (kN)	SHEAR Lbs. (kN)	TENSION Lbs. (kN)	SHEAR Lbs. (kN)	TENSION Lbs. (kN)	SHEAR Lbs. (kN)	TENSION Lbs. (kN)	SHEAR Lbs. (kN)
1/4 (6.4)	3.5 (4.7)	3/16 (4.8)	1-1/8 (28.6)	Carbon	1,120 (5.0)	1,215 (5.4)	1,120 (5.0)	1,215 (5.4)	1,120 (5.0)	1,215 (5.4)	1,120 (5.0)	1,215 (5.4)
				Stainless	640 (2.8)	1,620 (7.2)	640 (2.8)	1,620 (7.2)	640 (2.8)	1,620 (7.2)	640 (2.8)	1,620 (7.2)
3/8 (9.5)	15 (20.3)	5/16 (7.9)	1-1/2 (38.1)	Carbon	1,360 (6.0)	2,560 (11.4)	1,360 (6.0)	2,560 (11.4)	1,360 (6.0)	2,560 (11.4)	1,360 (6.0)	2,560 (11.4)
				Stainless	1,160 (5.2)	2,560 (11.4)	1,160 (5.2)	2,560 (11.4)	1,160 (5.2)	2,560 (11.4)	1,160 (5.2)	2,560 (11.4)
1/2 (12.7)	25 (33.9)	3/8 (9.5)	1-7/8 (47.6)	Carbon	N/A	N/A	2,220 (9.9)	3,500 (15.6)	N/A	N/A	2,220 (9.9)	3,500 (15.6)
				Stainless	N/A	N/A	2,100 (9.3)	3,500 (15.6)	N/A	N/A	2,100 (9.3)	3,500 (15.6)
5/8 (15.9)	55 (74.6)	1/2 (12.7)	2 (50.8)	Carbon	N/A	N/A	3,080 (13.7)	6,440 (28.6)	N/A	N/A	3,080 (13.7)	6,440 (28.6)
				Stainless	N/A	N/A	3,080 (13.7)	6,440 (28.6)	N/A	N/A	2,820 (12.5)	6,440 (28.6)
3/4 (19.1)	90 (122.0)	5/8 (15.9)	2-1/2 (63.5)	Carbon	N/A	N/A	4,200 (18.7)	10,200 (45.4)	N/A	N/A	4,200 (18.7)	10,200 (45.4)

\* Allowable values are based upon a 4 to 1 safety factor. Divide by 4 for allowable load values. The tabulated values are for anchors installed in a minimum of 12 diameters on center and a minimum edge distance of 6 diameters for 100 percent anchor efficiency. Spacing and edge distance may be reduced to 6 diameter spacing and 3 diameter edge distance, provided the values are reduced 50 percent. Linear interpolation may be used for intermediate spacings and edge distances.

### Combined Tension and Shear Loading—for Dynabolt Anchors

Allowable loads for anchors subjected to combined shear and tension forces are determined by the following equation:

$$(P_s/P_t) + (V_s/V_t) \leq 1$$

P<sub>s</sub> = Applied tension load

V<sub>s</sub> = Applied shear load

P<sub>t</sub> = Allowable tension load

V<sub>t</sub> = Allowable shear load

# Tapcon<sup>®</sup> Concrete and Masonry Anchors

THE ORIGINAL  
**Tapcon**



Blue Climaseal™

410 Stainless Steel

## DESCRIPTION/SUGGESTED SPECIFICATIONS

### Tapcon Anchors —

SPECIFIED FOR ANCHORAGE INTO CONCRETE, BRICK OR BLOCK

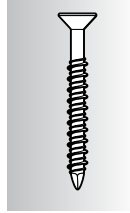

The “original masonry” anchor that cuts its own threads into concrete, brick, or block. Maximum performance is achieved because the Tapcon Anchor, the Condrive Installation Tool, and the carbide-tipped Tapcon Drill Bits are designed to work as a system. It is essential to use the Condrive tool and the correct drill bit to assure consistent anchor performance.

## ADVANTAGES

- Works in all masonry base materials.
- Fast and easy—3 anchors per minute.
- No hole spotting or inserts required.
- Removable.
- Slotted hex and phillips flat head styles.
- Extended corrosion protection—Blue Climaseal™.
- Available in 410 Stainless Steel.

### Tapcon Anchors

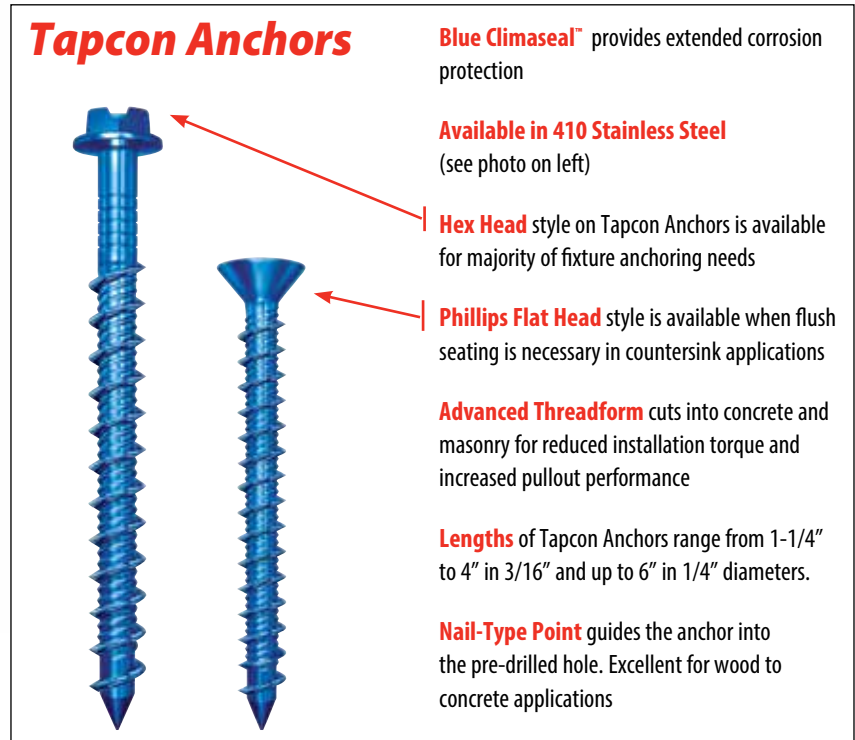

**Blue Climaseal™** provides extended corrosion protection

**Available in 410 Stainless Steel** (see photo on left)

**Hex Head** style on Tapcon Anchors is available for majority of fixture anchoring needs

**Phillips Flat Head** style is available when flush seating is necessary in countersink applications

**Advanced Threadform** cuts into concrete and masonry for reduced installation torque and increased pullout performance

**Lengths** of Tapcon Anchors range from 1-1/4" to 4" in 3/16" and up to 6" in 1/4" diameters.

**Nail-Type Point** guides the anchor into the pre-drilled hole. Excellent for wood to concrete applications

Tapcon® is a registered trademark of Buildex, a division of Illinois Tool Works, Inc.

## CORROSION RESISTANCE

### Kesternich Results (DIN 40018 2.0L)

30 Cycles - 10% or less rust

### Salt Spray Results (ASTM B117)

720 Hrs - 10% or less rust

## APPLICATIONS



The Tapcon Anchor is especially well suited for window and door frames because it performs well in block, is available in a flat head style, and is fast to install.



Many horizontal or "wall" applications are attached with Tapcon Anchor because it is removable and works well in block and brick.



The picture shows the Condrive 1000 Installation Kit in action. The kit makes for fast and easy change over from drill bit to driver and controls the driving torque to prevent thread stripping and head snapping in hard base materials.

## FEATURES

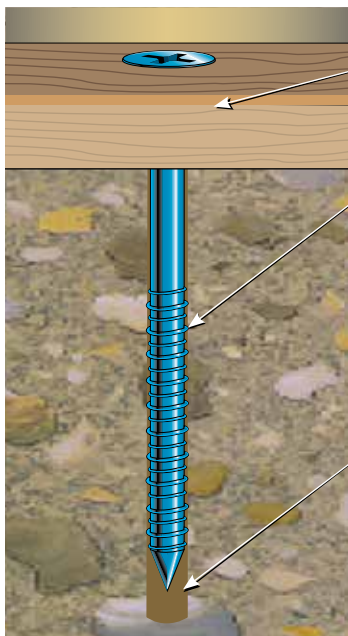

**Fixture Thickness**—determine the fixture thickness to be anchored

**Anchor Embedment**—with a minimum recommended embedment of 1", the correct Tapcon anchor choice can be made. Hole depth must be a minimum **1/4" deeper** than the anchor embedment to allow for displaced material

**Hole Diameter**—proper hole diameter is very important to insure consistent performance and maximum pullout strength. **3/16" anchors require 5/32" diameter bits, and 1/4" anchors require 3/16" diameter bits**

## APPROVAL/LISTINGS

### Blue Climaseal™

ICC Evaluation Service, Inc. – ESR-1671  
 ICC Evaluation Service, Inc. – ESR-2202  
 Miami-Dade County – NOA #12-0816.06  
 Florida Building Code

### 410 Stainless Steel

Miami-Dade County – NOA #12-0816.06  
 Florida Building Code

For the most current approvals/listings visit: [www.itw-redhead.com](http://www.itw-redhead.com)

## INSTALLATION STEPS

### Read installation instructions before using!



**WARNING:** If there are any questions concerning proper installation, applications or appropriate use of this product, please call our Technical Services Department at 1-800-848-5611. Failure to follow these instructions can result in serious personal injury.

1. **Select proper fastener – diameter / head style / length.**
  - a) **Use selection chart to choose proper length.**
2. **Drill Hole – use selection chart to determine drill bit length and depth of hole.**
  - a) **Choose appropriate drill of Tapcon Anchor.**
  - b) **Drill hole minimum 1/4" deeper than Tapcon Anchor to be embedded.**  
 Minimum anchor embedment: 1"  
 Maximum anchor embedment: 1-3/4"
3. **Drive Anchor.**



**WARNING:** Failure to wear safety glasses with side shields can result in serious personal injury. Always wear ANSI compliant eye protection (ANSI Z87.1-2003).



**WARNING:** Using the wrong size drill bit will affect performance values and may cause failure.

### Head Styles

3/16" diameter has a 1/4" slotted hex washer head (HWH)  
 1/4" diameter has a 5/16" slotted hex washer head (HWH)

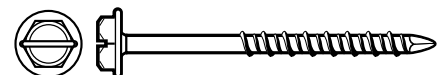

3/16" diameter uses a #2 phillips flat head (PFH)  
 1/4" diameter uses a #3 phillips flat head (PFH)





## SELECTION CHARTS

### Tapcon® Anchors with Blue Climaseal™

Diameter.....3/16" and 1/4"

Point Type.....Nail

All boxes of Tapcon anchors come packaged with matching carbide-tipped bit. Tapcon is packaged 100 pieces per box and 500 pieces per master carton except 3205407 and 3203407 (400 in master carton).

Thread Form.....Advanced Threadform Technology™

Finish.....Blue Climaseal™

FIXTURE THICKNESS INCHES	RECOMMENDED TAPCON LENGTH In. (mm)	PART NO. 3/16" HEX HEAD	PART NO. 1/4" HEX HEAD	PART NO. 3/16" FLAT HEAD	PART NO. 1/4" FLAT HEAD	BIT LENGTH In. (mm)	STRAIGHT SHANK BITS FOR 3/16" TAPCON PART NO.	STRAIGHT SHANK BITS FOR 1/4" TAPCON PART NO.
0" – 1/4"	1-1/4 (31.8)	3139407	3153407	3169407	3183407	3-1/2 (88.9)	-	3098910
1/4" – 3/4"	1-3/4 (44.5)	3141407	3155407	3171407	3185407	3-1/2 (88.9)	-	3098910
3/4" – 1-1/4"	2-1/4 (57.2)	3143407	3157407	3173407	3187407	4-1/2 (114.3)	3096910	3099910
1-1/4" – 1-3/4"	2-3/4 (69.9)	3145407	3159407	3175407	3189407	4-1/2 (114.3)	3096910	3099910
1-3/4" – 2-1/4"	3-1/4 (82.6)	3147407	3161407	3177407	3191407	5-1/2 (139.7)	3097910	3100910
2-1/4" – 2-3/4"	3-3/4 (95.3)	3149407	3163407	3179407	3193407	5-1/2 (139.7)	3097910	3100910
2-1/2" – 3"	4 (101.6)	N/A	3165407	3181407	3195407	5-1/2 (139.7)	3097910	3100910
3-1/2" – 4"	5 (127.0)	N/A	3167407	N/A	3197407	6-1/2 (165.1)	N/A	-
4-1/2" – 5"	6 (152.4)	N/A	3205407	N/A	3203407	7-1/2 (190.5)	N/A	3206910

Additional Tapcon bits are available 10 per tube.

### Tapcon® 410 SS Anchor

Diameter.....3/16" and 1/4"

Point Type.....Nail

All boxes of Tapcon anchors come packaged with matching carbide-tipped bit. Tapcon is packaged 100 pieces per box and 500 pieces per master carton except 3461907 (400 in master carton).

Thread Form.....Original Notched Hi-Lo™

Finish.....410 Stainless Steel with Silver Climaseal™

FIXTURE THICKNESS INCHES	RECOMMENDED TAPCON LENGTH In. (mm)	PART NO. 1/4" HEX HEAD	PART NO. 3/16" FLAT HEAD	PART NO. 1/4" FLAT HEAD	BIT LENGTH In. (mm)	STRAIGHT SHANK BITS FOR 3/16" TAPCON PART NO.	STRAIGHT SHANK BITS FOR 1/4" TAPCON PART NO.
0" – 1/4"	1-1/4 (31.8)	3367907	3434907	3373907	3-1/2 (88.9)	3095910	3098910
1/4" – 3/4"	1-3/4 (44.5)	3368907	3418907	3374907	3-1/2 (88.9)	3095910	3098910
3/4" – 1-1/4"	2-1/4 (57.2)	3369907	3419907	3375907	4-1/2 (114.3)	3096910	3099910
1-1/4" – 1-3/4"	2-3/4 (69.9)	3370907	3420907	3376907	4-1/2 (114.3)	3096910	3099910
1-3/4" – 2-1/4"	3-1/4 (82.6)	3371907	-	3377907	5-1/2 (139.7)	3097910	3100910
2-1/4" – 2-3/4"	3-3/4 (95.3)	3372907	3422907	3378907	5-1/2 (139.7)	3097910	3100910
2-1/2" – 3"	4 (101.6)	3459907	N/A	N/A	5-1/2 (139.7)	N/A	3100910
3-1/2" – 4"	5 (127.0)	3460907	N/A	N/A	6-1/2 (165.1)	N/A	3102910
4-1/2" – 5"	6 (152.4)	N/A	N/A	N/A	7-1/2 (190.5)	N/A	3461907

### Tapcon® SDS Bits

PART NUMBER	DESCRIPTION
3311910	7" (SDS Rotohammer Bits for use with 3/16" Tapcon)
7901060	5" (SDS Rotohammer Bits for use with 1/4" Tapcon)
3101910	7" (SDS Rotohammer Bits for use with 1/4" Tapcon)

All SDS bits are sold individually.

## PERFORMANCE TABLE

### Tapcon® Anchors

### Ultimate Tension and Shear Values (Lbs/kN) in Concrete

ANCHOR DIA. In. (mm)	MIN. DEPTH OF EMBEDMENT In. (mm)	f'c = 2000 PSI (13.8 MPa)		f'c = 3000 PSI (20.7 MPa)		f'c = 4000 PSI (27.6 MPa)		f'c = 5000 PSI (34.5 MPa)	
		TENSION Lbs. (kN)	SHEAR Lbs. (kN)	TENSION Lbs. (kN)	SHEAR Lbs. (kN)	TENSION Lbs. (kN)	SHEAR Lbs. (kN)	TENSION Lbs. (kN)	SHEAR Lbs. (kN)
3/16 (4.8)	1 (25.4)	600 (2.7)	720 (3.2)	625 (2.8)	720 (3.2)	650 (2.9)	720 (3.2)	800 (3.6)	860 (3.8)
	1-1/4 (31.8)	845 (3.7)	720 (3.2)	858 (3.8)	720 (3.2)	870 (3.9)	720 (3.2)	1,010 (4.5)	860 (3.8)
	1-1/2 (38.1)	1,090 (4.8)	860 (3.8)	1,090 (4.8)	860 (3.8)	1,090 (4.8)	860 (3.8)	1,220 (5.4)	860 (3.8)
	1-3/4 (44.5)	1,450 (6.5)	870 (3.9)	1,455 (6.5)	870 (3.9)	1,460 (6.5)	990 (4.4)	1,730 (7.7)	990 (4.4)
1/4 (6.4)	1 (25.4)	750 (3.3)	900 (4.0)	775 (3.4)	900 (4.0)	800 (3.6)	1,360 (6.1)	950 (4.2)	1,440 (6.4)
	1-1/4 (31.8)	1,050 (4.7)	900 (4.0)	1,160 (5.2)	900 (4.0)	1,270 (5.6)	1,360 (6.1)	1,515 (6.7)	1,440 (6.4)
	1-1/2 (38.1)	1,380 (6.1)	1,200 (5.3)	1,600 (7.2)	1,200 (5.3)	1,820 (8.1)	1,380 (6.1)	2,170 (9.7)	1,670 (7.4)
	1-3/4 (44.5)	2,020 (9.0)	1,670 (7.4)	2,200 (9.8)	1,670 (7.4)	2,380 (10.6)	1,670 (7.4)	2,770 (12.3)	1,670 (7.4)

Safe working loads for single installation under static loading should not exceed 25% of the ultimate load capacity.



## PERFORMANCE TABLES

### Tapcon® Anchors

### Ultimate Tension and Shear Values (Lbs/kN) in Hollow Block

ANCHOR DIA. In. (mm)	ANCHOR EMBEDMENT In. (mm)	LIGHTWEIGHT BLOCK		MEDIUM WEIGHT BLOCK	
		TENSION Lbs. (kN)	SHEAR Lbs. (kN)	TENSION Lbs. (kN)	SHEAR Lbs. (kN)
3/16 (4.8)	1 (25.4)	220 (1.0)	400 (1.8)	340 (1.5)	730 (3.2)
1/4 (6.4)	1 (25.4)	250 (1.1)	620 (2.8)	500 (2.2)	1,000 (4.4)

Safe working loads for single installation under static loading should not exceed 25% of the ultimate load capacity.

NOTE: 3/16" Tapcon requires 5/32" bit, 1/4" Tapcon requires 3/16" bit.

### Tapcon® Anchors

### Allowable Edge and Spacing Distances

PARAMETER	ANCHOR DIA. In. (mm)	NORMAL WEIGHT CONCRETE			CONCRETE MASONRY UNITS (CMU)		
		FULL CAPACITY (Critical Distance Inches)	REDUCED CAPACITY (Minimal Distance Inches)	LOAD REDUCTION FACTOR	FULL CAPACITY (Critical Distance Inches)	REDUCED CAPACITY (Minimal Distance Inches)	LOAD REDUCTION FACTOR
Spacing Between Anchors - Tension	3/16	3	1-1/2	0.73	3	1-1/2	1.00
	1/4	4	2	0.66	4	2	0.84
Spacing Between Anchors - Shear	3/16	3	1-1/2	0.83	3	1-1/2	1.00
	1/4	4	2	0.82	4	2	0.81
Edge Distance - Tension	3/16	1-7/8	1	0.83	4	2	0.91
	1/4	2-1/2	1-1/4	0.82	4	2	0.88
Edge Distance -Shear	3/16	2-1/4	1-1/8	0.70	4	2	0.93
	1/4	3	1-1/2	0.59	4	2	0.80

For Sl: 1 inch = 25.4 mm

## Tapcon® Condrive 1000 Tool Kit

### DESCRIPTION/SUGGESTED SPECIFICATIONS

#### Condrive 1000 Installation Tool— SPECIFIED FOR ANCHORAGE INTO CONCRETE, BRICK OR BLOCK

The key to Tapcon's fast and easy installation is the multi-purpose Condrive Installation Tool. The drive sleeve, along with the hex head and phillips sockets provide the installer with the flexibility necessary for the complete variety of Tapcon applications (tool does not include drill bit).

Condrive® 1000 - A multi-purpose tool designed for installation of Tapcon hex head and Phillips flat head anchors up to 3-3/4" long. If driving hex head Tapcon, driver will automatically disengage. The Condrive 1000 has a reusable plastic case.

Condrive Tools are designed to specifically install Tapcon Anchors and to fit standard hammer drills.

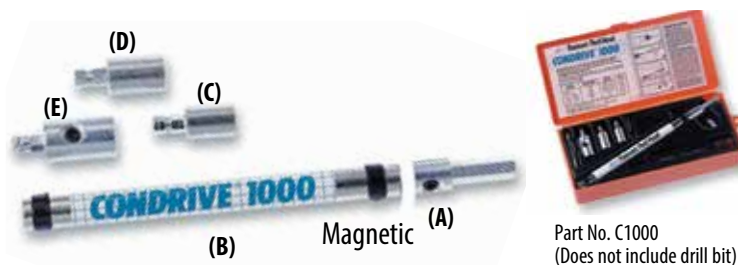

### APPLICATIONS



The picture shows the Condrive 1000 Installation Kit in action. The kit makes for fast and easy change over from drill bit to driver and controls the driving torque to prevent thread stripping and head snapping in hard base materials.

### ADVANTAGES

- Fast change from drilling to driving
- Eliminates need to change out chucks and bits
- Eliminates need for two tools
- Special nut driver is recessed for torque control to reduce head breakage

### Condrive 1000 Spare Parts

PART NO.	DESCRIPTION	QTY/WT
(A) 7901001	Drill Adapter	1/.06
(B) 7901002	Sleeve	1/.01
(C) 7901006	3/16" Socket	1/.04
(D) 7901007	1/4" Socket	1/.05
(E) 7901010	Phillips Socket	1/.44

# Tapcon® Maxi-Set Anchors



White UltraShield    UltraShield

## DESCRIPTION/SUGGESTED SPECIFICATIONS

FORTAPCON APPLICATIONS THAT REQUIRE MORE ANCHOR BEARING SURFACE.



## ADVANTAGES

- Same reliable performance and speed of installation as regular Tapcon.
- Large 5/8" diameter flange provides more bearing surface and increases pullover resistance. High 5/16" hex head adds driving stability.
- Compatible with DrivTru™ socket system. Improves installation. Protects paint finish.
- UltraShield™ and White UltraShield™ long-life finish deliver excellent corrosion resistance.

## CORROSION RESISTANCE

Salt Spray Test (ASTM B117)	UltraShield	White UltraShield
	1100 Hrs 10% or less rust	1500 Hrs NO RED RUST

## APPROVAL/LISTINGS

ICC Evaluation Service, Inc. – #ESR-1671  
Miami-Dade County – NOA #12-0816.06

For the most current approvals/listings visit: [www.itw-redhead.com](http://www.itw-redhead.com)

## INSTALLATION STEPS

Read installation instructions before using!



**WARNING:**

If there are any questions concerning proper installation, applications or appropriate use of this product, please call our Technical Services Department at 1-800-848-5611. Failure to follow these instructions can result in serious personal injury.

1. **Select proper fastener – diameter / head style / length.**
  - a) Use selection chart to choose proper length.
2. **Drill Hole – use selection chart to determine drill bit length and depth of hole.**
  - a) Choose appropriate drill of Tapcon Anchor.
  - b) Drill hole minimum ¼" deeper than Tapcon Anchor to be embedded.  
Minimum anchor embedment: 1"  
Maximum anchor embedment: 1-3/4"
3. **Drive anchor using 5/16" socket.**



**WARNING:**

Failure to wear safety glasses with side shields can result in serious personal injury. Always wear ANSI compliant eye protection (ANSI Z87.1-2003).



**WARNING:**

Using the wrong size drill bit will affect performance values and may cause failure.

## APPLICATIONS



Shutters - protective and decorative  
Screened porch and pool enclosures.  
Various sheet metal flashings.



Decorative wrought iron.  
Wood nailers and plywood attachment.

## SELECTION CHART

### Tapcon® Maxi-Set Anchors

Diameter.....1/4" Thread Form..... Advanced Threadform Technology™  
 Point Type.....Nail Finish.....UltraShield™ or \*White UltraShield™  
 Head Style.....5/16" across flats hex with 5/8" diameter flange.

### Tapcon® SDS Bits

PART NUMBER	DESCRIPTION
3311910	7" (SDS Rotohammer Bits for use with 3/16" Tapcon)
7901060	5" (SDS Rotohammer Bits for use with 1/4" Tapcon)
3101910	7" (SDS Rotohammer Bits for use with 1/4" Tapcon)

RECOMMENDED TAPCON LENGTH In. (mm)	PART NO. 1/4" HEX HEAD	FINISH	BIT LENGTH In. (mm)	STRAIGHT SHANK BITS FOR 1/4" TAPCON PART NO.
1-3/4 (44.5)	3294000	Ultra Shield	3-1/2 (88.9)	3098910
1-3/4 (44.5)	3383100	White Ultra Shield	3-1/2 (88.9)	3098910
2-1/4 (57.2)	3384100	White Ultra Shield	4-1/2 (114.3)	3099910
3-1/4 (82.6)	3409100	White Ultra Shield	5-1/2 (139.7)	3100910

NOTE: 2-3/4" and 3-1/4" lengths are special orders. Contact customer service for lead-times.  
 Maxi-Sets are packed 1,000 pieces per master carton except 3409100 is packed 750 pieces.

## PERFORMANCE TABLES

### Tapcon® Anchors

### Ultimate Tension and Shear Values (Lbs/kN) in Concrete

ANCHOR DIA. In. (mm)	MIN. DEPTH OF EMBEDMENT In. (mm)	f <sub>c</sub> = 2000 PSI (13.8 MPa)		f <sub>c</sub> = 3000 PSI (20.7 MPa)		f <sub>c</sub> = 4000 PSI (27.6 MPa)		f <sub>c</sub> = 5000 PSI (34.5 MPa)	
		TENSION Lbs. (kN)	SHEAR Lbs. (kN)	TENSION Lbs. (kN)	SHEAR Lbs. (kN)	TENSION Lbs. (kN)	SHEAR Lbs. (kN)	TENSION Lbs. (kN)	SHEAR Lbs. (kN)
1/4 (6.4)	1 (25.4)	750 (3.3)	900 (4.0)	775 (3.4)	900 (4.0)	800 (3.6)	1,360 (6.1)	950 (4.2)	1,440 (6.4)
	1-1/4 (31.8)	1,050 (4.7)	900 (4.0)	1,160 (5.2)	900 (4.0)	1,270 (5.6)	1,360 (6.1)	1,515 (6.7)	1,440 (6.4)
	1-1/2 (38.1)	1,380 (6.1)	1,200 (5.3)	1,600 (7.2)	1,200 (5.3)	1,820 (8.1)	1,380 (6.1)	2,170 (9.7)	1,670 (7.4)
	1-3/4 (44.5)	2,020 (9.0)	1,670 (7.4)	2,200 (9.8)	1,670 (7.4)	2,380 (10.6)	1,670 (7.4)	2,770 (12.3)	1,670 (7.4)

Safe working loads for single installation under static loading should not exceed 25% of the ultimate load capacity. Divide by 4

### Tapcon® Anchors

### Ultimate Tension and Shear Values (Lbs/kN) in Hollow Block

ANCHOR DIA. In. (mm)	ANCHOR EMBEDMENT In. (mm)	LIGHTWEIGHT BLOCK		MEDIUM WEIGHT BLOCK	
		TENSION Lbs. (kN)	SHEAR Lbs. (kN)	TENSION Lbs. (kN)	SHEAR Lbs. (kN)
1/4 (6.4)	1 (25.4)	250 (1.1)	620 (2.8)	500 (2.2)	1,000 (4.4)

Safe working loads for single installation under static loading should not exceed 25% of the ultimate load capacity. Divide by 4.

NOTE: 3/16" Tapcon requires 5/32" bit, 1/4" Tapcon requires 3/16" bit.

### Tapcon® Anchors

### Allowable Edge and Spacing Distances

PARAMETER	ANCHOR DIA. In. (mm)	NORMAL WEIGHT CONCRETE			CONCRETE MASONRY UNITS (CMU)		
		FULL CAPACITY (Critical Distance Inches)	REDUCED CAPACITY (Minimal Distance Inches)	LOAD REDUCTION FACTOR	FULL CAPACITY (Critical Distance Inches)	REDUCED CAPACITY (Minimal Distance Inches)	LOAD REDUCTION FACTOR
Spacing Between Anchors - Tension	1/4	4	2	0.66	4	2	0.84
Spacing Between Anchors - Shear	1/4	4	2	0.82	4	2	0.81
Edge Distance - Tension	1/4	2-1/2	1-1/4	0.82	4	2	0.88
Edge Distance - Shear	1/4	3	1-1/2	0.59	4	2	0.80

For SI: 1 inch = 25.4 mm

# Tapcon® SCOTS Anchors



## DESCRIPTION/SUGGESTED SPECIFICATIONS

PREMIUM CONCRETE ANCHOR THAT COMBINES THE CORROSION PROTECTION OF STAINLESS STEEL WITH THE PERFORMANCE OF TAPCON ANCHORS.



## ADVANTAGES

- 300 Series Stainless Steel head and Carbon Steel body.
- Integral washer design provides more bearing surface.
- Rubber EPDM sealing washer "locks-out" moisture from building interior.
- Head paint available in white or bronze (extra charge).
- Delivers the same holding performance as Tapcon anchors with Blue Climaseal™.
- Reduces replacement of "weathered" fasteners.

## CORROSION RESISTANCE

Kesternich Results (DIN 50018, 2.0L)

Climaseal™ 30 Cycles - 10% or less red rust

## APPROVAL/LISTINGS

ICC Evaluation Service, Inc. – ESR-1671

Miami-Dade County – #12-0816.06

For the most current approvals/listings visit: [www.itw-redhead.com](http://www.itw-redhead.com)

## INSTALLATION STEPS

Read installation instructions before using!



**WARNING:**

If there are any questions concerning proper installation, applications or appropriate use of this product, please call our Technical Services Department at 1-800-848-5611. Failure to follow these instructions can result in serious personal injury.

1. **Select proper fastener – diameter / head style / length.**
  - a) Use selection chart to choose proper length.
2. **Drill Hole – use selection chart to determine drill bit length and depth of hole.**
  - a) Choose appropriate drill of Tapcon Anchor.
  - b) Drill hole minimum 1/4" deeper than Tapcon Anchor to be embedded.
    - Minimum anchor embedment: 1"
    - Maximum anchor embedment: 1-3/4"
3. **Drive anchor using 5/16" socket.**



**WARNING:**

Failure to wear safety glasses with side shields can result in serious personal injury. Always wear ANSI compliant eye protection (ANSI Z87.1-2003).



**WARNING:**

Using the wrong size drill bit will affect performance values and may cause failure.

## APPLICATIONS



Shutters - protective and decorative



Screened porch and pool enclosures

Aluminum fixtures

Railings

Metal roofing

Flexible flashings



## SELECTION CHART

		Diameter.....1/4"	Thread Form..... Advanced Threadform Technology™
		Point Type.....Nail	Finish.....Silver Climaseal™
		Head Style.....5/16" HWH (300 Series Stainless)	
RECOMMENDED TAPCON LENGTH In. (mm)	PART NO. 1/4" HEX HEAD	BIT LENGTH In. (mm)	STRAIGHT SHANK BITS FOR 1/4" TAPCON PART NO.
1-3/4 (44.5)	3358407	3-1/2 (88.9)	3098910

NOTE: 2-3/4" and 3-1/4" lengths are special orders. Contact customer service for lead-times.  
SCOTS are packed 1,000 pieces per master, 100 pieces per inner.

3311910	7" (SDS Rotohammer Bits for use with 3/16" Tapcon)
7901060	5" (SDS Rotohammer Bits for use with 1/4" Tapcon)
3101910	7" (SDS Rotohammer Bits for use with 1/4" Tapcon)

## PERFORMANCE TABLES

		<b>Ultimate Tension and Shear Values (Lbs/kN) in Concrete</b>							
		f <sub>c</sub> = 2000 PSI (13.8 MPa)		f <sub>c</sub> = 3000 PSI (20.7 MPa)		f <sub>c</sub> = 4000 PSI (27.6 MPa)		f <sub>c</sub> = 5000 PSI (34.5 MPa)	
ANCHOR DIA. In. (mm)	MIN. DEPTH OF EMBEDMENT In. (mm)	TENSION Lbs. (kN)	SHEAR Lbs. (kN)	TENSION Lbs. (kN)	SHEAR Lbs. (kN)	TENSION Lbs. (kN)	SHEAR Lbs. (kN)	TENSION Lbs. (kN)	SHEAR Lbs. (kN)
1/4 (6.4)	1 (25.4)	750 (3.3)	900 (4.0)	775 (3.4)	900 (4.0)	800 (3.6)	1,360 (6.1)	950 (4.2)	1,440 (6.4)
	1-1/4 (31.8)	1,050 (4.7)	900 (4.0)	1,160 (5.2)	900 (4.0)	1,270 (5.6)	1,360 (6.1)	1,515 (6.7)	1,440 (6.4)
	1-1/2 (38.1)	1,380 (6.1)	1,200 (5.3)	1,600 (7.2)	1,200 (5.3)	1,820 (8.1)	1,380 (6.1)	2,170 (9.7)	1,670 (7.4)
	1-3/4 (44.5)	2,020 (9.0)	1,670 (7.4)	2,200 (9.8)	1,670 (7.4)	2,380 (10.6)	1,670 (7.4)	2,770 (12.3)	1,670 (7.4)

Safe working loads for single installation under static loading should not exceed 25% of the ultimate load capacity.

## Tapcon® Anchors Ultimate Tension and Shear Values (Lbs/kN) in Hollow Concrete Masonry Units

ANCHOR DIA. In. (mm)	ANCHOR EMBEDMENT In. (mm)	LIGHTWEIGHT BLOCK		MEDIUM WEIGHT BLOCK	
		TENSION Lbs. (kN)	SHEAR Lbs. (kN)	TENSION Lbs. (kN)	SHEAR Lbs. (kN)
1/4 (6.4)	1 (25.4)	250 (1.1)	620 (2.8)	500 (2.2)	1,000 (4.4)

Safe working loads for single installation under static loading should not exceed 25% of the ultimate load capacity.

NOTE: 3/16" Tapcon requires 5/32" bit, 1/4" Tapcon requires 3/16" bit.

## Tapcon® Anchors Allowable Edge and Spacing Distances

PARAMETER	ANCHOR DIA. In. (mm)	NORMAL WEIGHT CONCRETE			CONCRETE MASONRY UNITS (CMU)		
		FULL CAPACITY (Critical Distance Inches)	REDUCED CAPACITY (Minimal Distance Inches)	LOAD REDUCTION FACTOR	FULL CAPACITY (Critical Distance Inches)	REDUCED CAPACITY (Minimal Distance Inches)	LOAD REDUCTION FACTOR
Spacing Between Anchors - Tension	1/4	4	2	0.66	4	2	0.84
Spacing Between Anchors - Shear	1/4	4	2	0.82	4	2	0.81
Edge Distance - Tension	1/4	2-1/2	1-1/4	0.82	4	2	0.88
Edge Distance - Shear	1/4	3	1-1/2	0.59	4	2	0.80

For SI: 1 inch = 25.4 mm

# Tapcon® XL Anchors



UltraShield    White UltraShield

## APPLICATIONS



Shutters - protective and decorative



Screened porch and pool enclosures.

Railings

Mounted electrical equipment

Sill plates



## DESCRIPTION/SUGGESTED SPECIFICATIONS

**EXTRA LARGE TAPCON FOR EXTRA LARGE CHALLENGES!**

## ADVANTAGES

- Internal TORX® T-40 drive assures easy installation.
- High button head resists cam-out during installation.
- Corrosion protection of UltraShield™ and White UltraShield™ to combat aggressive environments.
- Available in silver or white to complement standard fixtures.
- Delivers over 3,000 lbs. holding power in concrete.
- Alternative to sleeve anchors.
- 1/4" SDS Tapcon drill bit for added convenience.
- Condrive® XL with MegaGrip™ bit holder for rapid one-tool installation.

## CORROSION RESISTANCE

Salt Spray Test (ASTM B117)	UltraShield	White UltraShield
	1100 Hrs 10% or less rust	1500 Hrs no red rust

## INSTALLATION STEPS

Read installation instructions before using!



**WARNING:**

If there are any questions concerning proper installation, applications or appropriate use of this product, please call our Technical Services Department at 1-800-848-5611. Failure to follow these instructions can result in serious personal injury.

1. **Select proper fastener – diameter / head style / length.**
  - a) Use selection chart to choose proper length.
2. **Drill Hole – use selection chart to determine drill bit length and depth of hole.**
  - a) Choose appropriate drill of Tapcon Anchor.
  - b) Drill hole minimum 1/4" deeper than Tapcon Anchor to be embedded.  
Minimum anchor embedment: 1"  
Maximum anchor embedment: 1-3/4"
3. **Insert the adjustable MegaGrip bit tip holder in the small opening of sleeve. Slide the open end of the Condrive XL Installation Tool sleeve over the drill bit and snap in place.**
4. **Drive anchor using MegaGrip adjustable magnetic bit holder with TORX T-40 bit tip**



MegaGrip PART#	DESCRIPTION
3400910	MegaGrip Bit Holder



**WARNING:**

Failure to wear safety glasses with side shields can result in serious personal injury. Always wear ANSI compliant eye protection (ANSI Z87.1-2003).



**WARNING:**

Using the wrong size drill bit will affect performance values and may cause failure.



## SELECTION CHART

**Tapcon®**  
**XL Anchors**

Diameter.....5/16"      Thread Form..... Reverse Hi-Lo®  
Point Type.....Nail      Finish.....UltraShield™ or \*White UltraShield™  
Head Style.....High button with TORX T-40 Drive

RECOMMENDED TAPCON LENGTH In. (mm)	PART NO.	FINISH	BIT LENGTH In. (mm)	1/4" DRILL BITS FOR TAPCON XL PART NO.
2-1/4 (57.2)	3395902	Ultra Shield	6-3/4" SDS drill bit with hex	3394910

XLs are packed 100 pieces per master carton.

PART NO.	DESCRIPTION	CARTON QTY
3401910	Condrive® XL Installation Tool with MegaGrip™ Bit Holder with TORX® T-40 Bit Tip	10 per master carton
3400910	MegaGrip™ Magnetized Bit Holder with TORX T-40 Bit Tip	10 per bag
3394910	1/4" x 6-3/4" SDS Tapcon Drill Bit with Hex	1 piece per tube

Tapcon XL Anchors must be installed using all Red Head system components (Tapcon XL Anchors, Condrive XL Installation Tool and Tapcon Drill Bits) in order to qualify for ITW Red Head system support.

## PERFORMANCE TABLES

**Tapcon®**  
**XL Anchors**

### Ultimate Tension and Shear Values (Lbs/kN) in Concrete

ANCHOR DIA. In. (mm)	MIN. DEPTH OF EMBEDMENT In. (mm)	EDGE DISTANCE	f'c = 3000 PSI (20.7 MPa)	
			TENSION Lbs. (kN)	SHEAR Lbs. (kN)
5/16 (7.9)	1-1/4 (31.8)	1-9/16 (39.7)	1,050 (4.7)	1,330 (5.9)
		2-3/16 (55.6)	1,205 (5.4)	1,725 (7.7)
	1-3/4 (44.5)	1-9/16 (39.7)	2,020 (9.0)	1,530 (6.8)
		2-3/16 (55.6)	2,250 (10.0)	2,505 (11.1)
	2-1/4 (57.2)	1-9/16 (39.7)	2,850 (12.7)	1,955 (8.9)
		2-3/16 (55.6)	3,120 (13.9)	3,250 (14.4)

Safe working loads for single installation under static loading should not exceed 25% of the ultimate load capacity. Divide by 4.

- Pilot hole diameter shall be 0.263" and drilled 1/4" longer than the necessary embedment.
- Allowable loads are based ultimate test load divide by 4.
- Recommended center to center distance of 3-3/4" is required for 100% efficiency and 1-7/8" for 50% efficiency.
- Embedment is through 1-1/4" face shell of hollow block.

**Tapcon®**  
**XL Anchors**

### Ultimate Tension & Shear Values in Concrete Masonry Units

ANCHOR DIA. In. (mm)	MINIMUM DEPTH OF EMBEDMENT In. (mm)	EDGE DISTANCE (Inches)	HOLLOW CORE <sup>1</sup>		GROUT-FILLED <sup>2</sup>	
			TENSION Lbs. (kN)	SHEAR Lbs. (kN)	TENSION Lbs. (kN)	SHEAR Lbs. (kN)
5/16 (7.9)	1-1/4 (31.8)	4	1,045 (4.6)	2,280 (10.1)	1,045 (4.6)	2,280 (10.1)
	1-3/4 (44.5)	4	NOT RECOMMENDED	NOT RECOMMENDED	1,950 (8.7)	2,825 (12.6)
	2-1/4 (57.2)	4	NOT RECOMMENDED	NOT RECOMMENDED	3,770 (16.8)	3,140 (14.0)

Safe working loads for single installation under static loading should not exceed 25% of the ultimate load capacity.

1 CMU = 1,600 PSI minimum compressive strength.

2 CMU = 1,600 PSI minimum compressive strength with 2,000 PSI grout.

# Tapcon® Storm Guard Anchors



## DESCRIPTION/SUGGESTED SPECIFICATIONS

DIRECT MOUNT PERMANENT ANCHORS FOR QUICK AND EASY INSTALLATIONS OF METAL AND PLYWOOD PANELS TO CONCRETE AND BLOCK.



## ADVANTAGES

- White UltraShield™ for corrosion protection in coastal environments.
- 1/4-20 x 7/8" external thread above collar.
- No caulking required.
- Threaded chamfered safety collar prevents overdriving.
- 3/16" Hex Drive.
- Use with ANSI standard 3/16" carbide-tipped drill bit. (bit not included)

## CORROSION RESISTANCE

Salt Spray Test (ASTM B117)    **White UltraShield**  
1500 Hrs no red rust

## APPROVAL/LISTINGS

Miami-Dade County – #11-0616.04

For the most current approvals/listings visit: [www.itw-redhead.com](http://www.itw-redhead.com)

## INSTALLATION STEPS

Read installation instructions before using!



**CAUTION:**

**DO NOT BEND DRILL BIT.**  
**DO NOT FORCE THE DRILL BIT INTO BASE MATERIAL.**

3/16" Nut Driver Installation Tool  
(Part # 3426910)



**WARNING:**

Failure to wear safety glasses with side shields can result in serious personal injury. Always wear ANSI compliant eye protection (ANSI Z87.1-2003).



**WARNING:**

Using the wrong size drill bit will affect performance values and may cause failure.

## APPLICATIONS



Direct mount permanent anchors for quick and easy installations for metal and plywood panels to wood, hollow block and concrete.

# Tapcon® Storm Guard Anchors

## SELECTION CHART

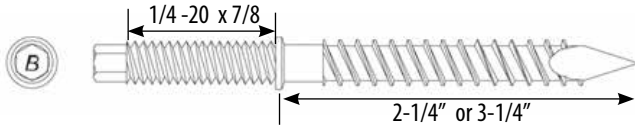

<b>Tapcon® Storm Guard Anchors</b>		Diameter.....1/4"	Thread Form..... Original Notched Hi-Lo™
		Point Type.....Nail	Finish.....UltraShield™
PART NO.	DESCRIPTION	COATING	BOX QTY
3424100	1/4" dia. x 2-1/4"	White UltraShield	1,000
3426910	3/16" Nut Driver	---	1

## PERFORMANCE TABLES

<b>Tapcon® Storm Guard Anchors</b>		<b>Ultimate Tension and Shear Values (Lbs/kN) in Concrete</b>			
ANCHOR DIA. In. (mm)	MIN. DEPTH OF EMBEDMENT In. (mm)	EDGE DISTANCE	f'c = 3000 PSI (20.7 MPa)		
			TENSION Lbs. (kN)	SHEAR Lbs. (kN)	
1/4 (6.4)	1 (25.4)	1-1/4 (31.8)	1,230 (5.5)	1,339 (6.0)	
	1 (25.4)	2-1/2 (63.5)	1,701 (7.6)	2,333 (10.4)	
	1-3/4 (44.5)	1-1/4 (31.8)	2,704 (12.0)	1,375 (6.1)	
	1-3/4 (44.5)	2-1/2 (63.5)	2,844 (12.6)	2,618 (11.6)	

Safe working loads for single installation under static loading should not exceed 25% of the ultimate load capacity. Divide by 4.

<b>Tapcon® Storm Guard Anchors</b>		<b>Ultimate Tension and Shear Values (Lbs/kN) in Hollow Concrete Masonry Units</b>		
ANCHOR DIA. In. (mm)	MIN. DEPTH OF EMBEDMENT In. (mm)	EDGE DISTANCE	f'c = 1500 PSI (10.4 MPa)	
			TENSION Lbs. (kN)	SHEAR Lbs. (kN)
1/4 (6.4)	1-1/4 (31.8)	1-1/4 (31.8)	1,955 (8.7)	536 (2.4)
	1-1/4 (31.8)	2-1/2 (63.5)	1,940 (8.6)	1,088 (4.8)

<b>Tapcon® Storm Guard Anchors</b>		<b>Ultimate Tension and Shear Values (Lbs/kN) in Grout-Filled (CMU)</b>		
ANCHOR DIA. In. (mm)	MIN. DEPTH OF EMBEDMENT In. (mm)	EDGE DISTANCE	GROUT-FILLED (CMU) f'c = 2000 PSI (13.8 MPa)	
			TENSION Lbs. (kN)	SHEAR Lbs. (kN)
1/4 (6.4)	1-3/4 (44.5)	1-1/4 (31.8)	3,335 (14.8)	1,207 (5.4)
	1-3/4 (44.5)	2-1/2 (63.5)	3,779 (16.8)	2,061 (9.2)

# Hammer-Set<sup>TM</sup> Anchors

## Nail-Drive Anchors



### APPLICATIONS



\*For overhead applications refer to page 79 for Redi-Drive information and performance data

NOT FOR USE IN OVERHEAD APPLICATIONS\*

- Electrical boxes
- Conduit clips
- Drywall track
- Roof flashing

\*For spacing and edge distance data please refer to the Tapcon data tables

### DESCRIPTION/SUGGESTED SPECIFICATIONS

## Hammer-Set Nail Drive Anchors—

SPECIFIED FOR ANCHORAGE INTO CONCRETE



Hammer-Set  
Nail-Drive  
Anchor

The Hammer-Set one-piece zinc plated steel anchor consists of an expansion body and expander drive pin. Anchors meet or exceed GSA specification A-A-1925A Type 1. (Formerly GSA: FF-S-325 Group V, Type 2, Class 3)

### ADVANTAGES

- Fast, easy installation
- Works in concrete, block and brick
- Install through material to be fastened
- Low profile mushroom head style

### APPROVALS/LISTINGS

Meets or exceeds GSA specification A-A-1925A Type 1 (Formerly GSA: FF-S-325 Group V, Type 2, Class 3)

### INSTALLATION STEPS

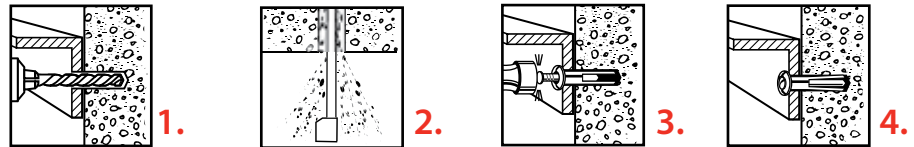

1. Drill proper size hole through material to be fastened into base material. (See Chart for bit size).
2. Clean hole.
3. Insert Hammer-Set into hole until head of anchor body is flush with material to be fastened. Tap the nail until flush with head of anchor. Ensure minimum embedment is 1/4" deeper than anchor embedment. Be sure head is firmly against fixture
4. Anchor is now set. \*\* NOT RECOMMENDED FOR OVERHEAD \*\*

### SELECTION CHART

## Hammer-Set

PART NUMBER	DESCRIPTION In. (mm)	DRILL SIZE In. (mm)	MAX. FIXTURE THICKNESS In. (mm)	MIN. EMBEDMENT In. (mm)	MIN. HOLE DEPTH In. (mm)	QTY/WT PER BOX lbs.	QTY/WT PER MASTER CTN - lbs.
HS-1607	3/16 x 7/8 (4.8 x 22.2)	3/16 (4.8)	1/4 (6.4)	5/8 (15.9)	1-1/8 (28.6)	100/ 2.0	1000/ 20
HS-1406	1/4 x 3/4 (6.4 x 19.1)	1/4 (6.4)	1/8 (3.2)	5/8 (15.9)	1 (25.4)	100/ 2.2	1000/ 22
HS-1410	1/4 x 1 (6.4 x 25.4)	1/4 (6.4)	1/4 (6.4)	3/4 (19.1)	1-1/4 (31.8)	100/ 2.4	1000/ 24
HS-1412	1/4 x 1-1/4 (6.4 x 31.8)	1/4 (6.4)	1/2 (12.7)	3/4 (19.1)	1-1/2 (38.1)	100/ 2.6	1000/ 26
HS-1414	1/4 x 1-1/2 (6.4 x 38.1)	1/4 (6.4)	3/4 (19.1)	3/4 (19.1)	1-3/4 (44.5)	100/ 2.8	1000/ 28
HS-1420	1/4 x 2 (6.4 x 50.8)	1/4 (6.4)	1-1/4 (31.8)	3/4 (19.1)	2-1/4 (57.2)	100/ 3.5	1000/ 35

### PERFORMANCE TABLE

## Hammer-Set

**Ultimate Tension and Shear  
Values in Concrete (Lbs/kN)**

ANCHOR DIA. In. (mm)	MIN. DEPTH OF EMBEDMENT In. (mm)	4000 PSI (27.6 MPa)	
		TENSION Lbs. (kN)	SHEAR Lbs. (kN)
3/16" (4.8)	5/8" (15.9)	500 (2.2)	450 (2.0)
1/4" (6.4)	5/8" (15.9)	700 (3.1)	700 (3.1)
1/4" (6.4)	3/4" (19.1)	800 (3.5)	800 (3.5)
1/4" (6.4)	1" (25.4)	950 (4.2)	800 (3.5)
1/4" (6.4)	1-1/4" (31.8)	1,100 (4.9)	1,100 (4.9)

Safe working loads for single installations under static loading conditions should not exceed 25% of the ultimate capacity. Divide ultimate values by 4.

**ITW Red Head**

Call our toll free number 800-848-5611 or visit our web site for the most current product and technical information at [www.itwredhead.com](http://www.itwredhead.com)